



INSTALLATION INSTRUCTIONS

SEGWAY

FUGLEMAN UT10 E(X)



SAFETY INSTRUCTIONS

READ PROPERLY COMPLETE ASSEMBLY INSTRUCTIONS BEFORE STARTING OF ASSEMBLY

Warning: Failure to heed all safety and operating instructions and warnings regarding use of this product can result in serious bodily injury.

Install all parts indicated in assembly instructions. Failure to fully assemble product before use could result in personal injury.

Assembly of product requires use of hand or power tools. If you are not experienced in using these types of tools, have product dealer do the install for you.

Some parts contain sharp edges, wear protective gloves if necessary. Always keep your assembly area clean, uncluttered and well lit.

Keep visitors and children a safe distance away from the assembly area. Visitors should wear the same safety equipment described under.

Never operate your UTV with the cab doors open. Failure to properly latch the doors before moving the vehicle could result in serious injury.

Dress for safety. DO NOT wear loose clothing, gloves, neckties or jewelry if using power tools to assemble this product. Insert all nut covers after you finish installation.

Never drive your UTV with the cab front window in open position.

Failure of improperly latched/locked front window before driving the vehicle could result in serious injury.

MAINTENANCE AND CLEANING

To clean polycarbonate surface use soapy water solution or other subtle means.

Dirt and dust wash by gently water stream and swipe only with wet or damp means in the direction from top to bottom.

The recommended frequency of cleaning of polycarbonate part is about 1 time per month or according to the actual degree of pollution.

Do not use detergents that could scratch the surface plates (abrasives, harsh fabrics, etc.).

Do not use solvents or alkaline detergents or cleaners with ammonia (ammonium hydroxide).

Do not remove the impurities from the surface of the razor blades or other sharp items.

Do not clean cabin, when the polycarbonate plates are heated by the sun.

Do not use the squeegee. It could be scratched surface plates.

Do not clean the water current strength greater than 50 bar (WAP).

The manufacturer is not responsible for scratching the surface in case of failure to comply with the above instructions.

All bolted connections of cab must be checked and tightened by user at regular intervals.

It is necessary to check the air filter of the heater regularly, depending on the dust environment in which the vehicle is operated.

PREPARATION FOR INSTALLATION

Uninstall all additional systems from the roller cages (work lights, rear mirrors, drink holders etc.)

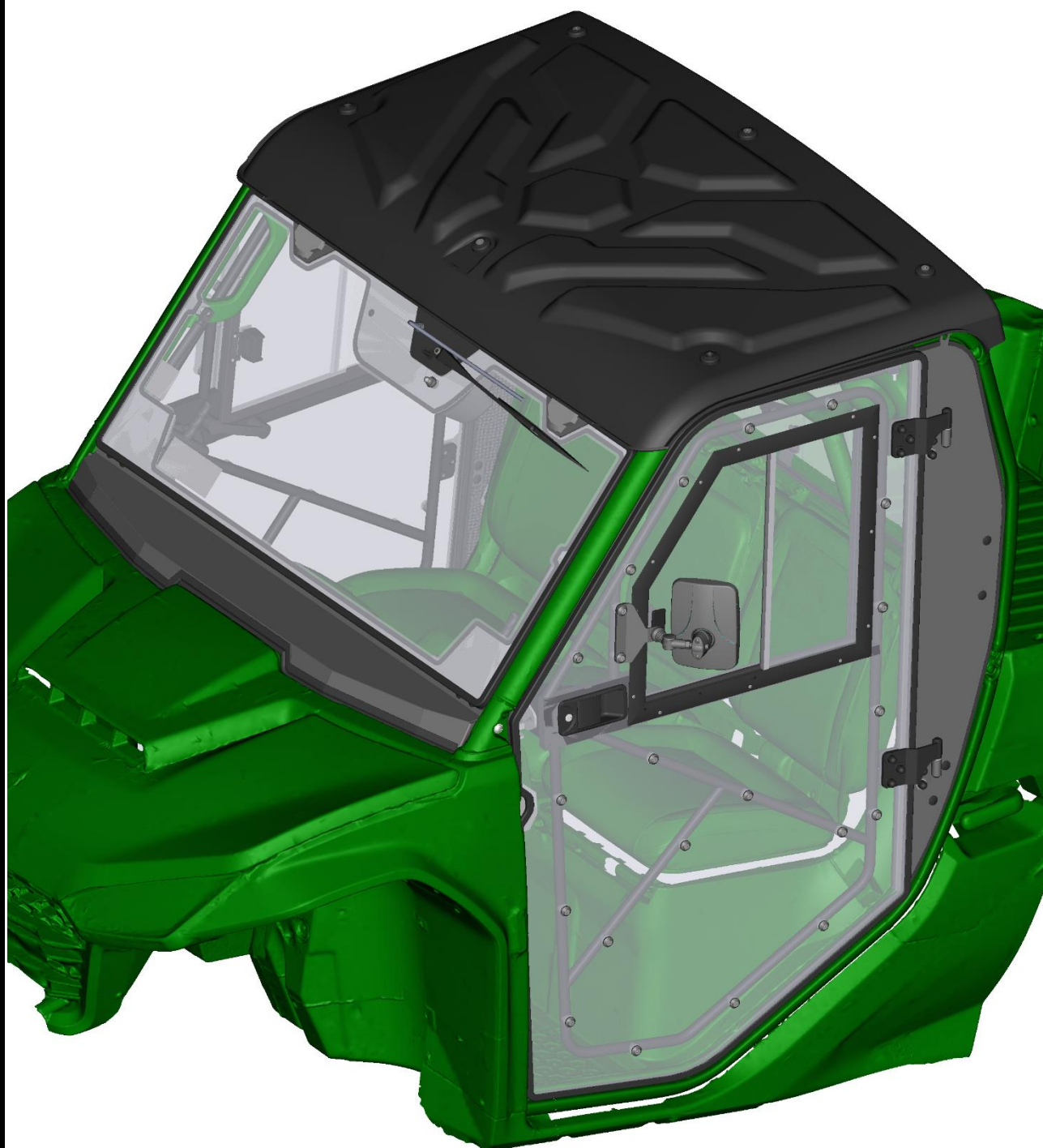

4

CAB PREVIEW

5

ELECTROINSTALLATION 1.

Uninstall the original box from the dashboard.



Uninstall the floor tunnel cover from the vehicle.



Uninstall the right seat from the vehicle.



7

Uninstall the plastic front cap cover.
Place the relay harness near the original fuse box.



Install the relay assembly with the vehicle by original fixing point.

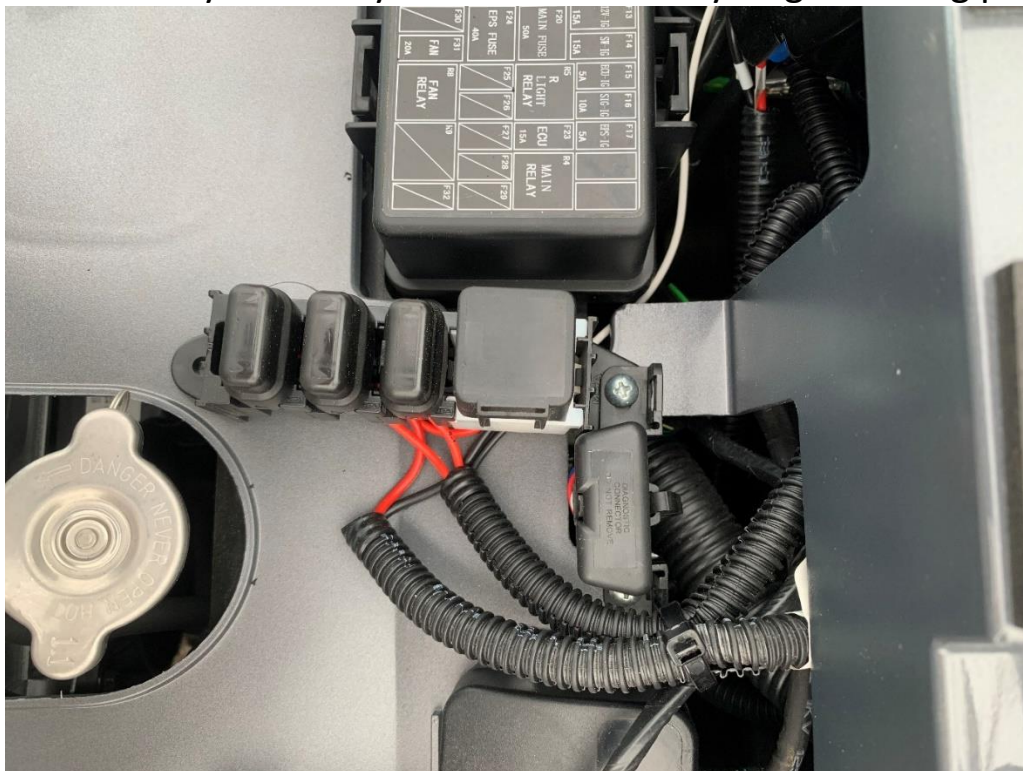

Install the washer tank holder onto the vehicle frame
by original fixing point.



Connect the relay harness with the original electro-installation.
Red wire with the +12V (red mark), black wire with the -12V (green mark).



Push out the original switch.



10

Find the free original pin.



Connect the relay harness with the free pin on the switch.



Insert the wiper harness into the inner dashboard space.
Connect the harness with the washer tank.



SEE NEXT PAGES

Connect the wiper harness with the relay harness.

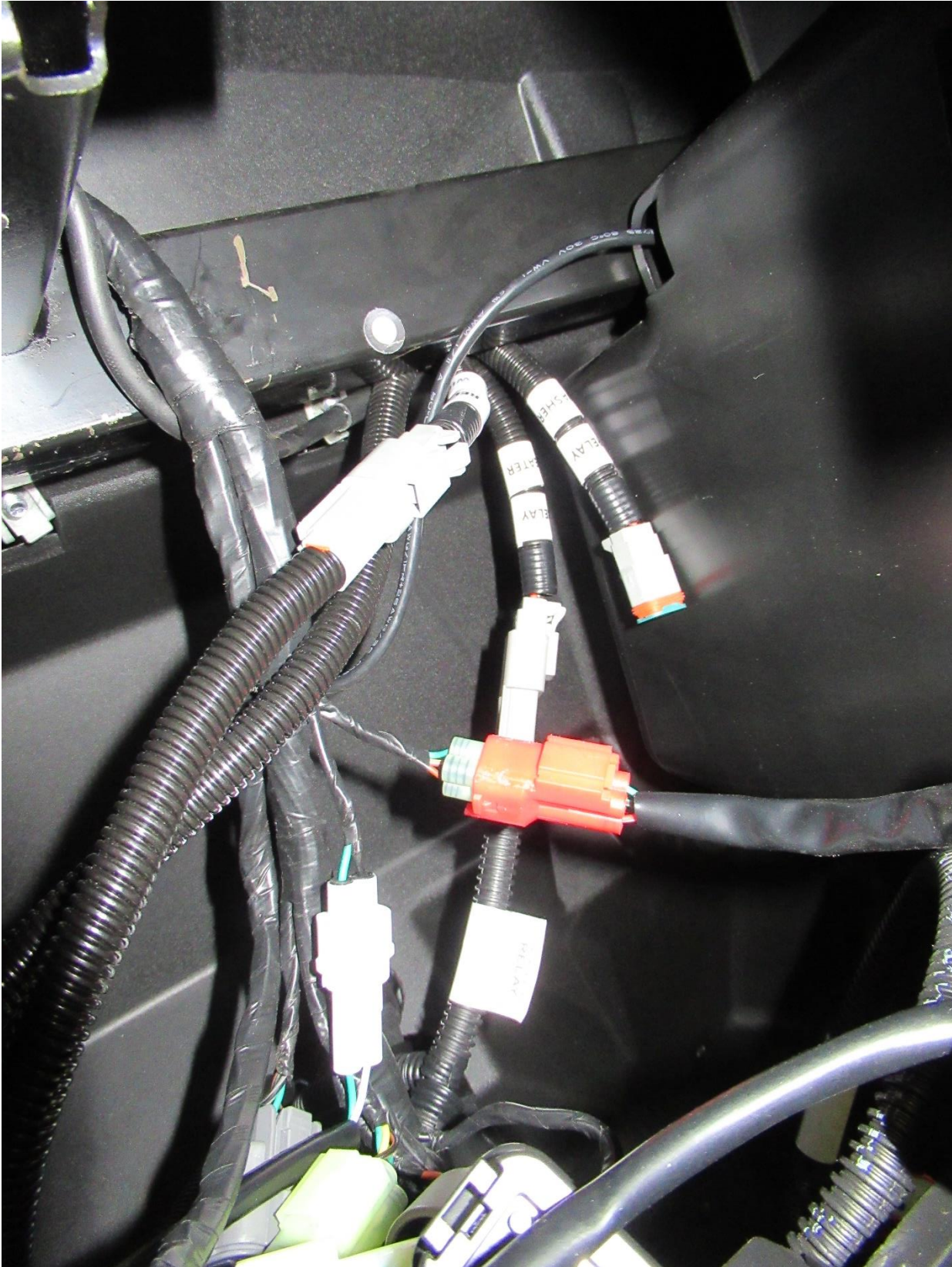

12

Run the wiper harness from the dashboard to the right seat through the floor tunnel.



SEE NEXT PAGES

13

Run the wiper harness to the right rear vehicle frame.



Run the wiper harness around the vehicle frame. (Harness marked by dashed line - - - - run under the plastic cover)



15

HEATER 1.

WARNING: FOR SUCCESSFUL AND COMPLETE INSTALLATION OF THE DFK HEATER ASSEMBLY, IT IS NECESSARY TO MOUNT DFK TILT-OUT FRONT PANEL P/N 74S02U01S10, OR DFK FRONT PANEL P/N 74S02R01S10

Drill 3 holes \varnothing 25mm into the inner plastic wall.

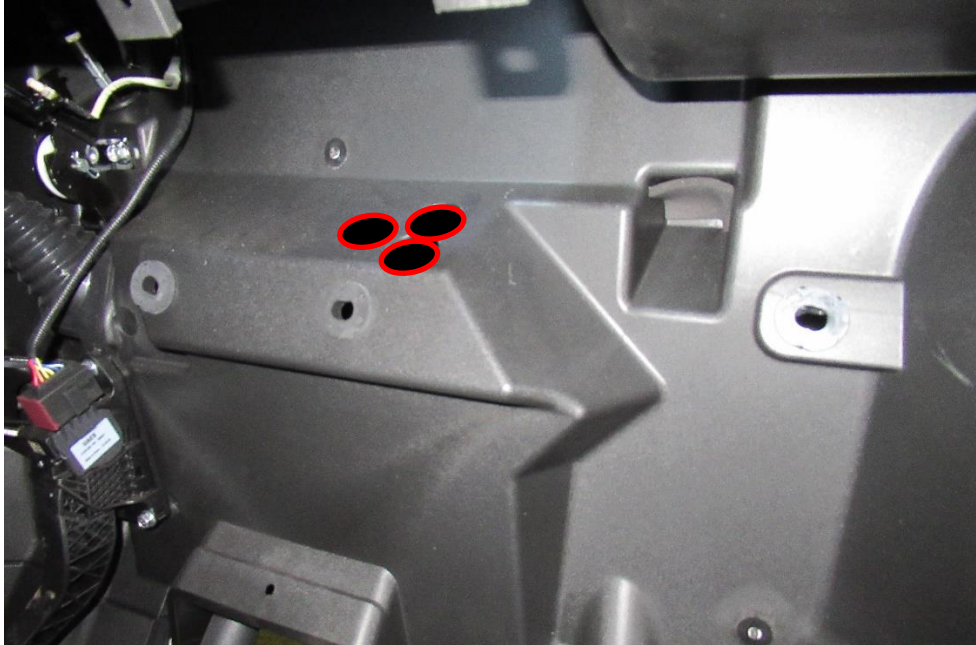

Insert the tightening rings onto the heater hoses. Insert the heater hoses onto the heater tubes. Secure the hoses with the heater by the rings.



Cut the heater hose and insert tightening rings onto the hose.
Insert air-bleeding valve into the heater hose.
Secure the valve with the hose by tightening rings from previous step.

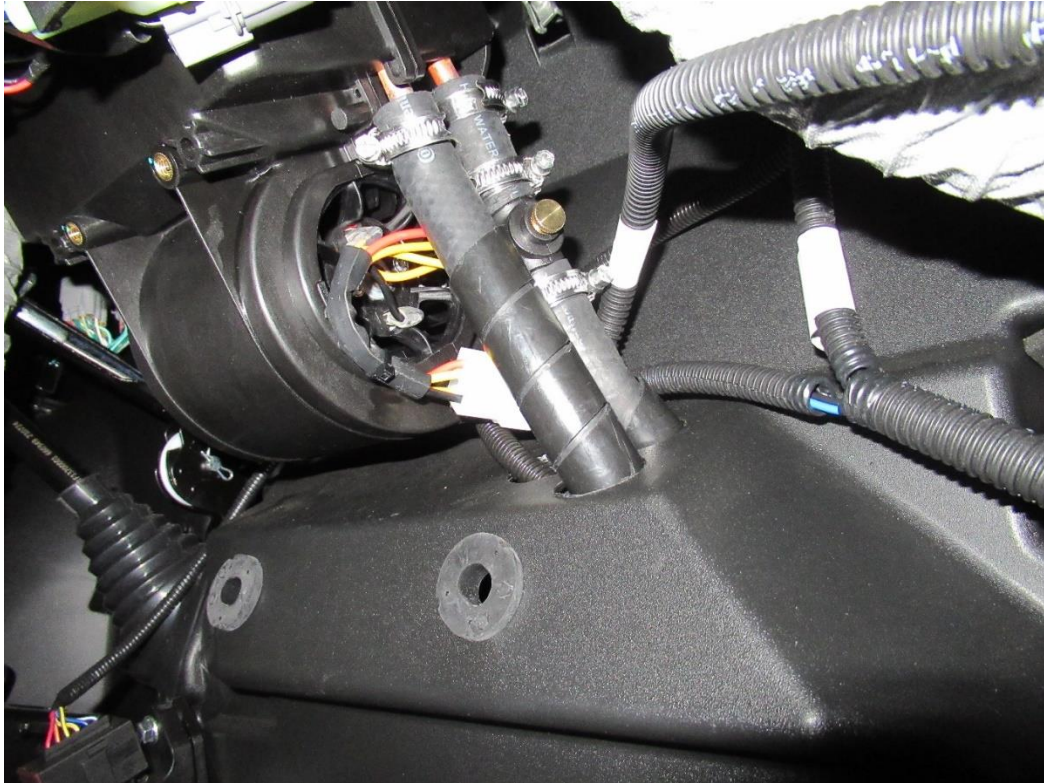

SEE NEXT PAGES

17

Insert the heater hoses into the drilled holes.



Insert the heater harness into the inner dashboard space.



19

Run the heater hose through the floor tunnel to the engine space.



20 Install the el. valve and the water pump into the heater hose. Run the heater harness to the el. valve. Connect the heater harness with the el. valve and with the water pump.

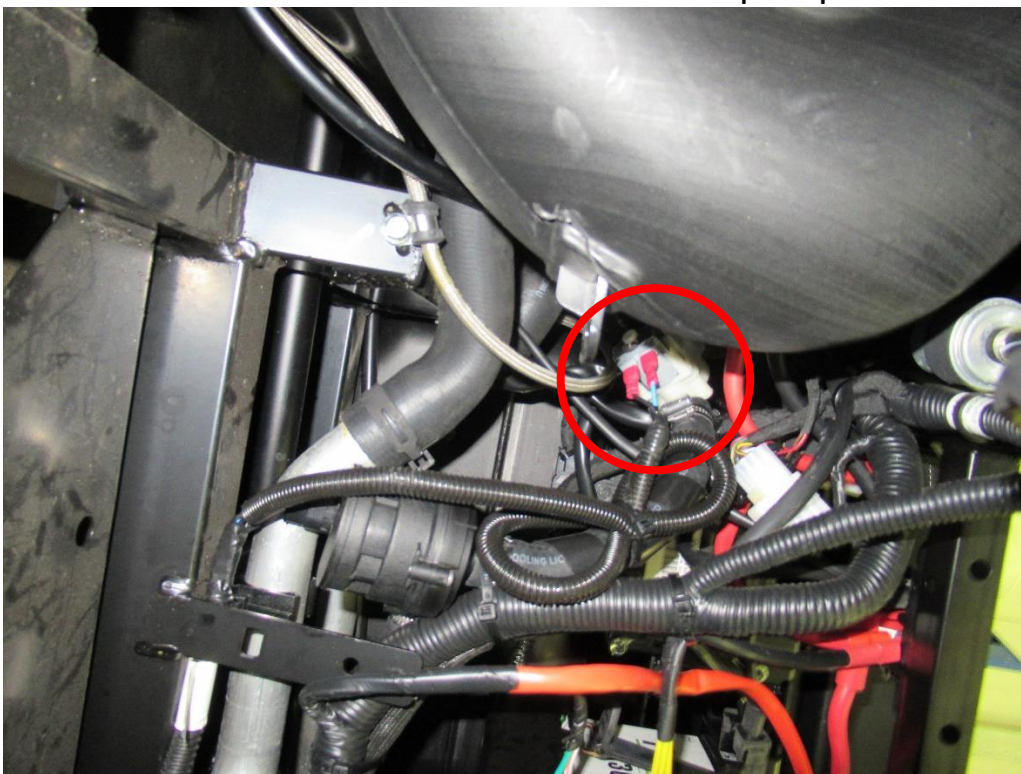

Connect the heater harness with the heater.



21

CAUTION

DO NOT MANIPULATE WITH ENGINE OR WITH ENGINE COOLING SYSTEM IF THAT PARTS OF MACHINE IS HOT! WHEN ENGINE IS HOT, ANY MANIPULATION CAN RESULT IN SERIOUS BODY INJURY!

Insert tightening ring onto the heater hose. Insert the “Y” tube into the heater hose (red mark). Secure the original engine cooling hose (green mark) by clamps or pliers (not included). Cut the cooling hose and insert tightening ring onto the hose. Insert the “Y” tube into the cooling hose. Secure tube with the hoses by tightening rings.

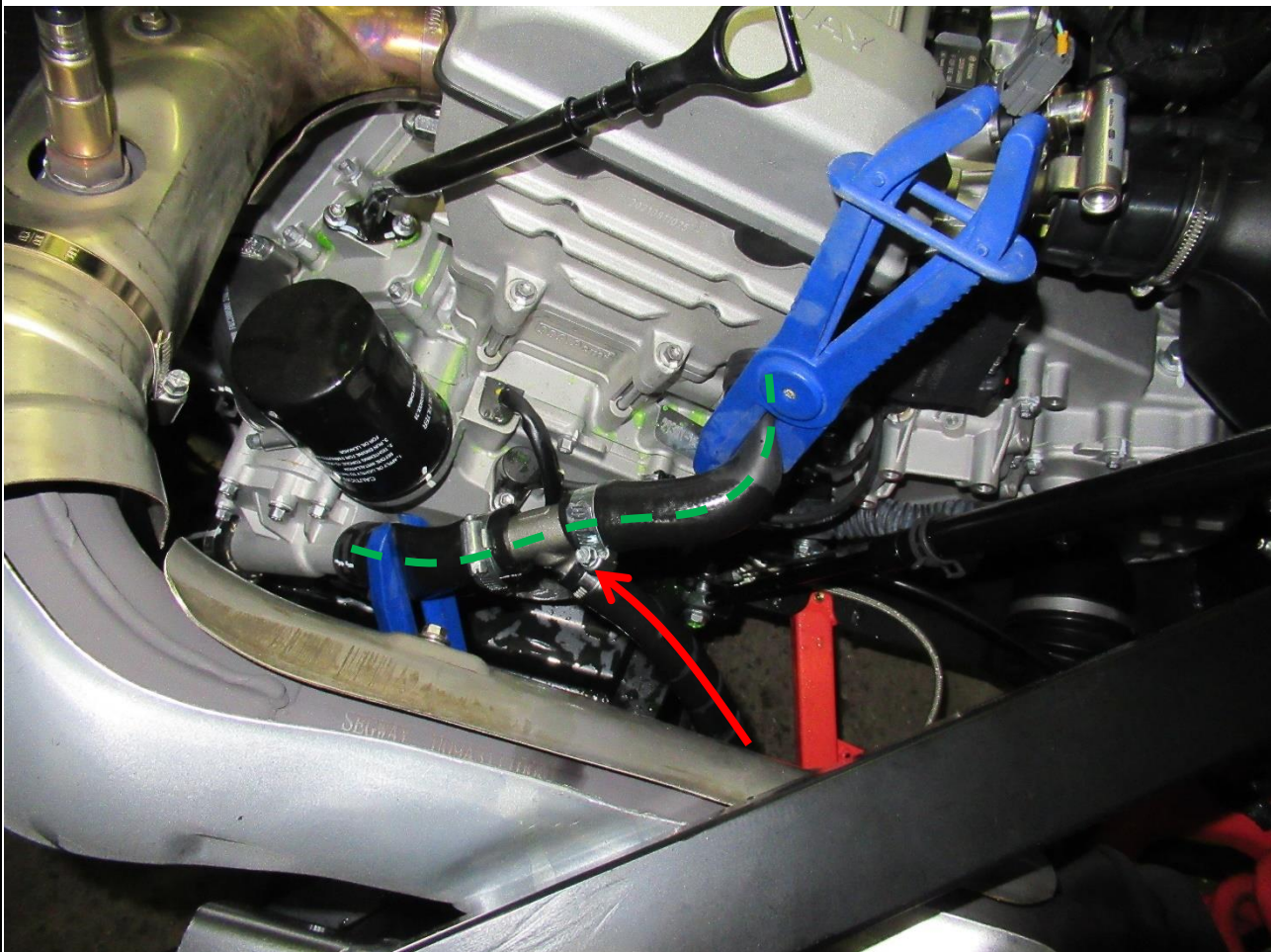

Run the heater hose from the heater to the front right wheel space.

Insert tightening ring onto the heater hose. Insert the “Y” tube into the heater hose (**red mark**). Secure the original engine cooling hose (**green mark**) by clamps or pliers (not included). Cut the cooling hose and insert tightening ring onto the hose. Insert the “Y” tube into the cooling hose. Secure tube with the hoses by tightening rings.

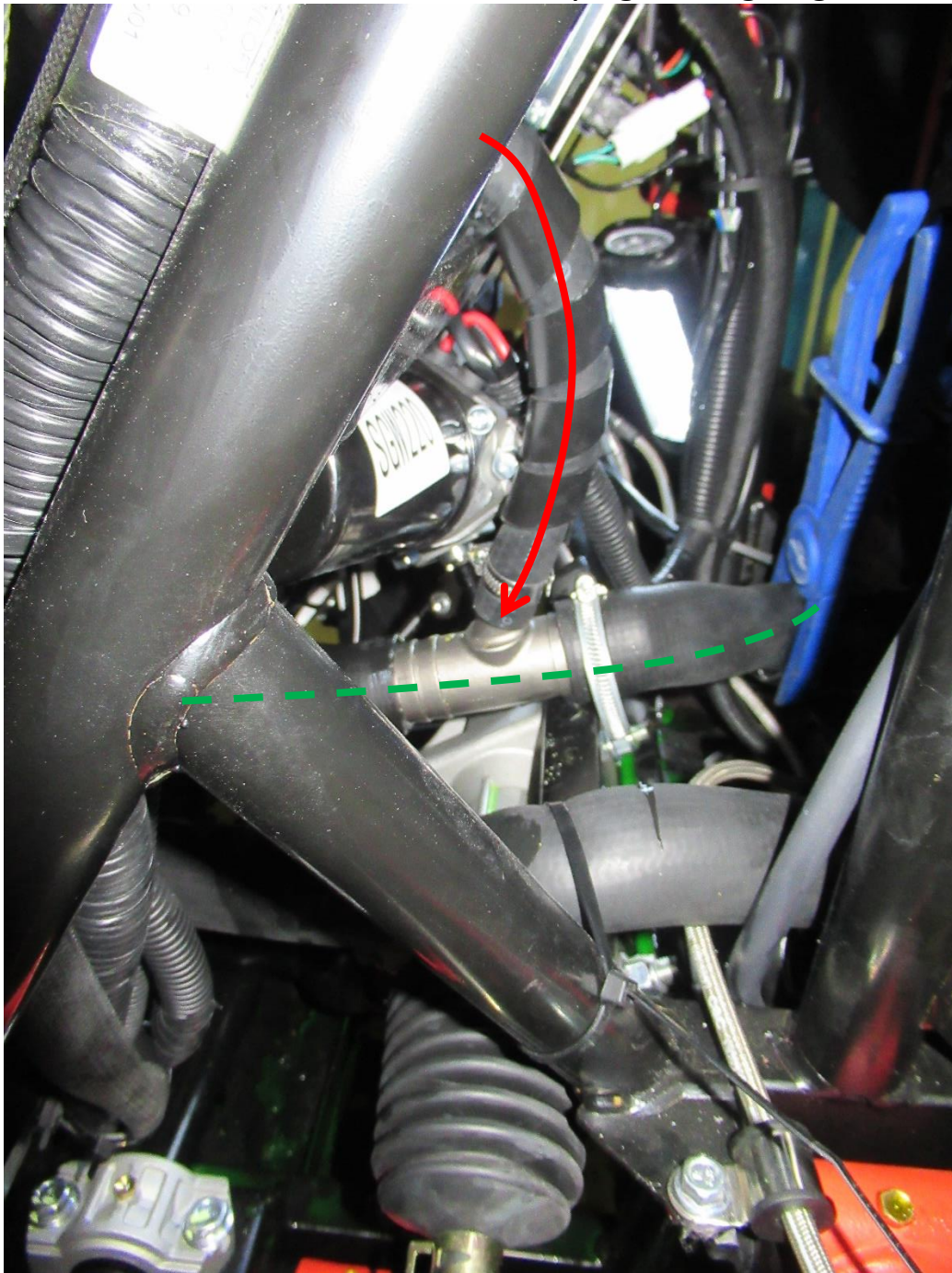

Install the heater with the holder onto the vehicle frame.



Push the air hoses into the inner dashboard space.



Drill 2 holes $\varnothing 55\text{mm}$ into the dashboard plastic wall. Run the air hoses through the drilled holes.



Connect the heater harness with the switches on the cover.



Install the air hoses onto the air vent and secure the hose with the vent by included tightening ring.

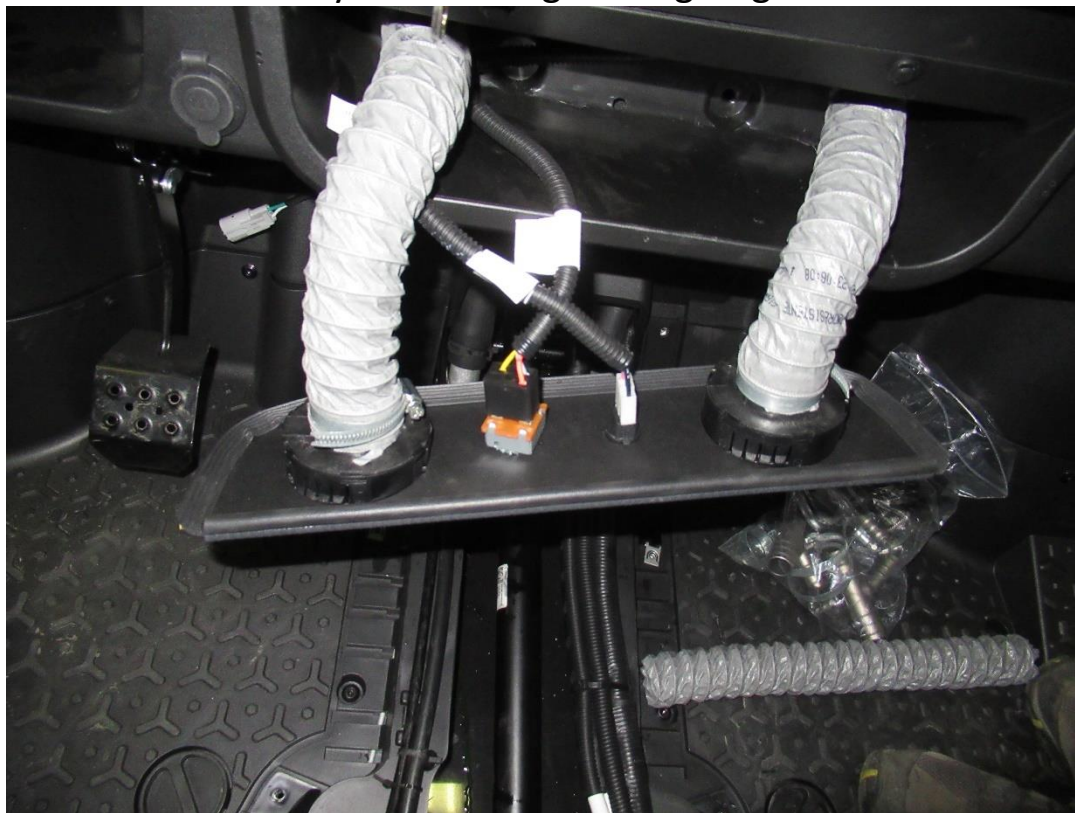

Place the cover onto the dashboard and fix the cover by included screws.



Take out the original warning sticks from the dashboard.

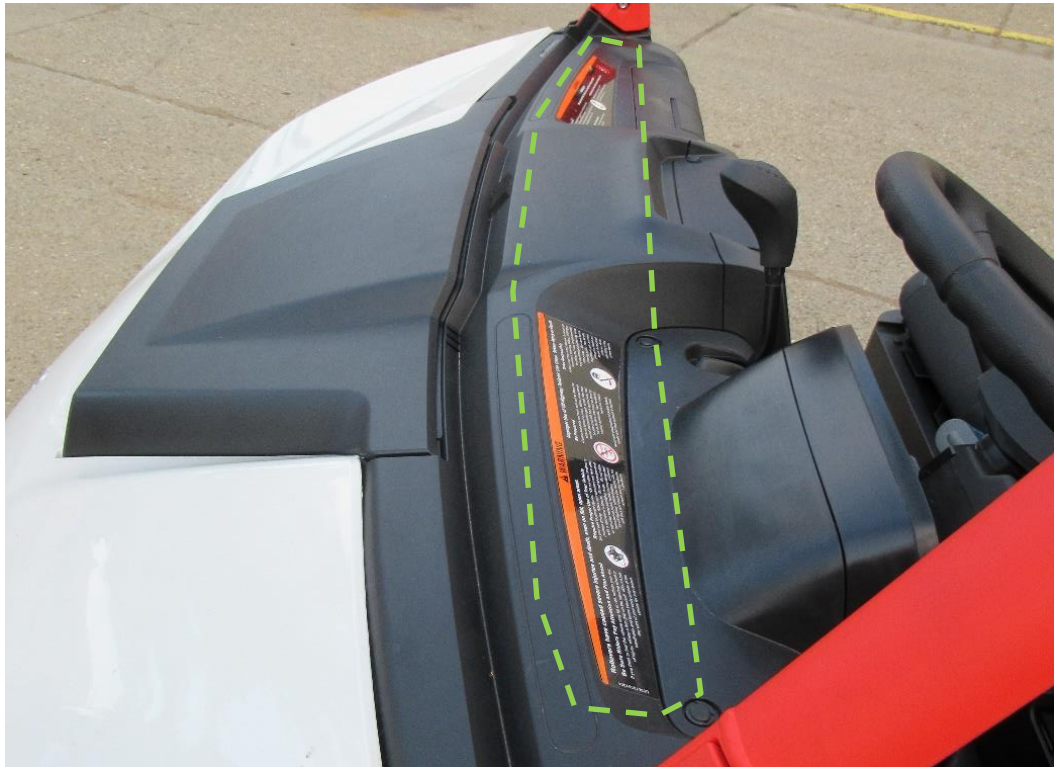

27

Install the original warning sticks onto the DFK front upper ledge.
(View on installed front upper ledge)

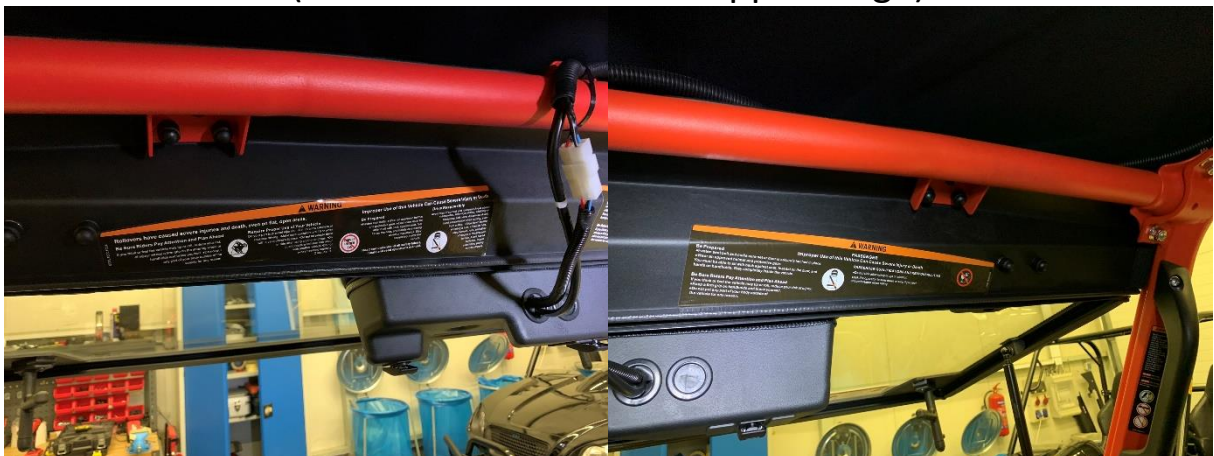

SEE NEXT PAGE

Drill 2 holes $\varnothing 55\text{mm}$ into the dashboard upper cover.

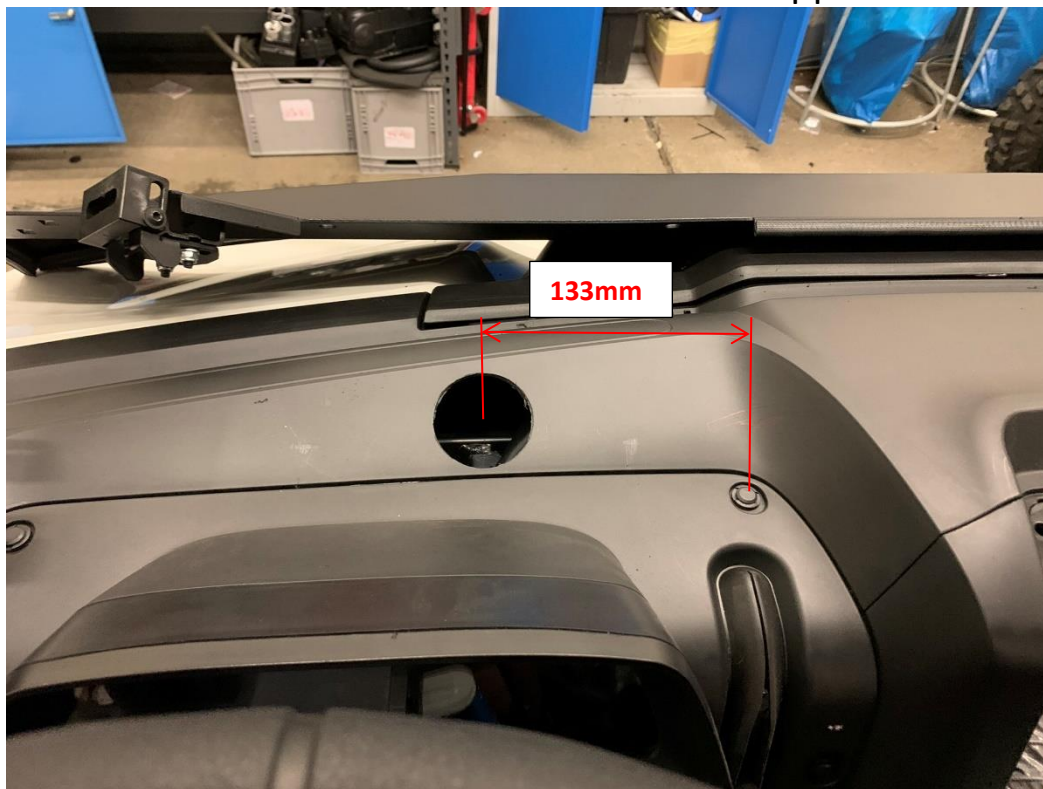

View onto the right side of the dashboard.

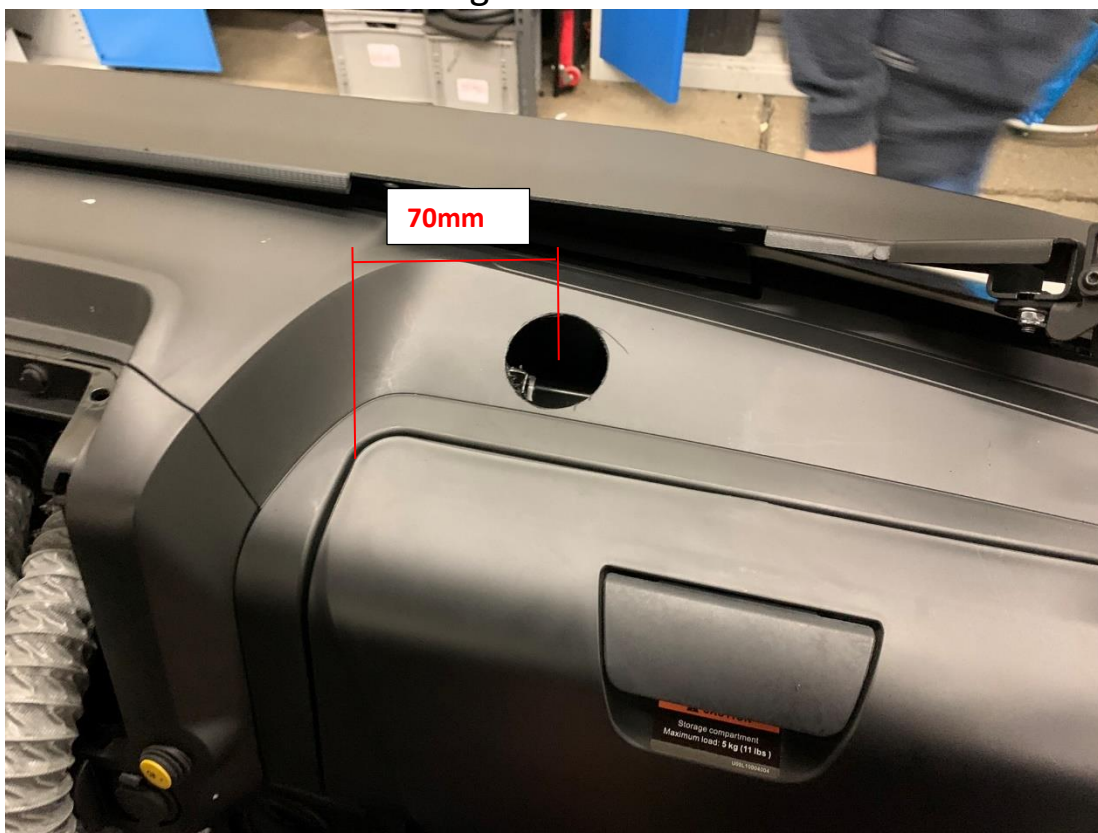

Run the air hose through the hole. Install the hose onto the air vent assembly.



View onto the right side of the dashboard.



FOR NEXT STEPS IT IS NECESSARY FRONT BOTTOM LEDGE
Fix the heater air vent cover with the front ledge by included fixing kit.

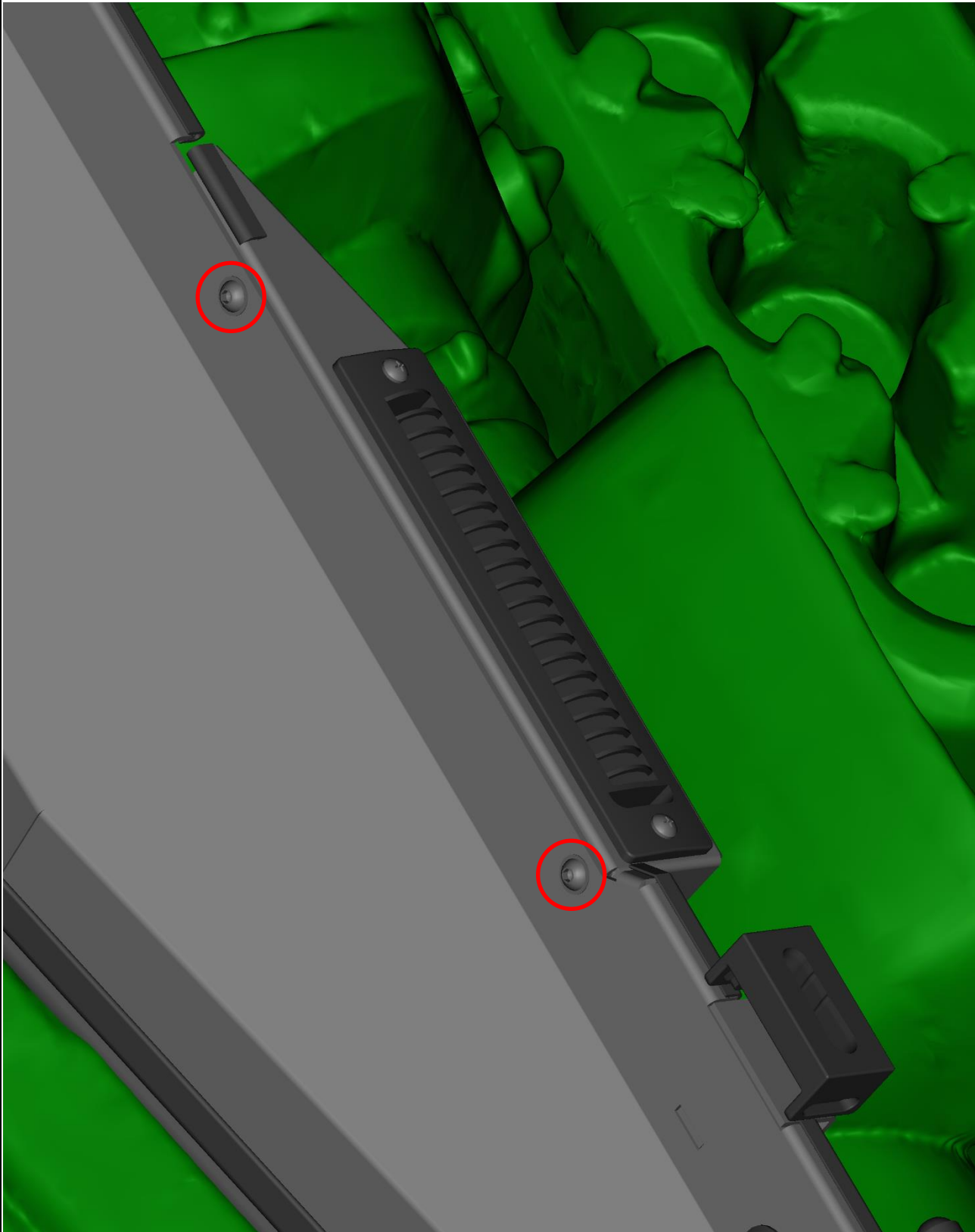

INNER SIDE VIEW



31

BLEEDING INSTRUCTIONS

- After installing the heater circuit, open the radiator and coolant reservoir of the vehicle and add coolant to both the coolant reservoir and radiator level is up to the MAX line.
- Install coolant reservoir and radiator caps.
- Activate heater fan, turn on the electromagnetic valve and put the heating level to maximum.
- Run engine at idle with coolant reservoir cap ON until the cooling fan cycles two times.
- If a DFK bleeding valve is included in the heater assembly, open it at nominal RPM until a continuous stream of fluid flows out of it.

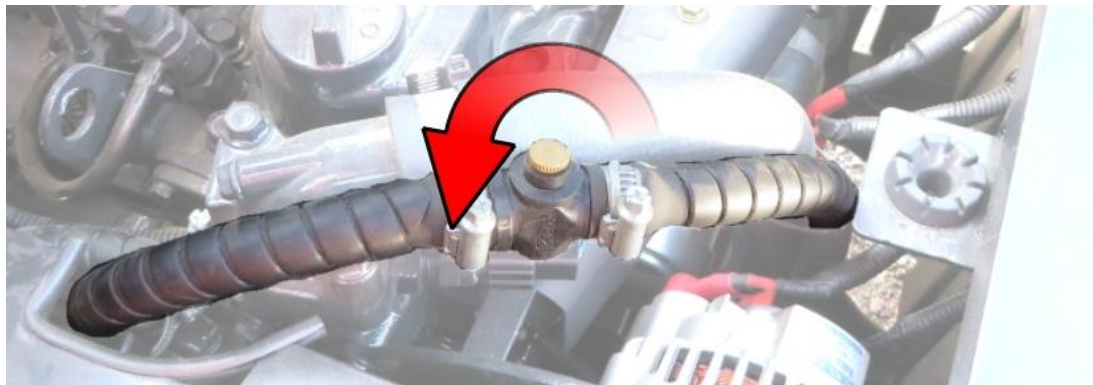

- Bleed even after the engine has warmed up to operating engine temperature and repeat several times until full flow, without air bubbles, escapes from the bleed plug holes.
- Check for heat coming out of the heater unit.
- Turn the ignition switch off and allow the engine to cool down.
- After the engine cools down check the coolant level in the radiator reserve tank.
- Close all coolant containers and bleeding valve before driving.
- After the test drive, check the coolant level in the radiator reserve tank and add coolant as necessary.
- Check for leaks in the entire heating circuit. Leaks can cause additional aeration.

FRONT PANEL

Place the front upper ledge onto the vehicle frame. Fix the ledge with the frame by included screws, washers, nuts and covers.

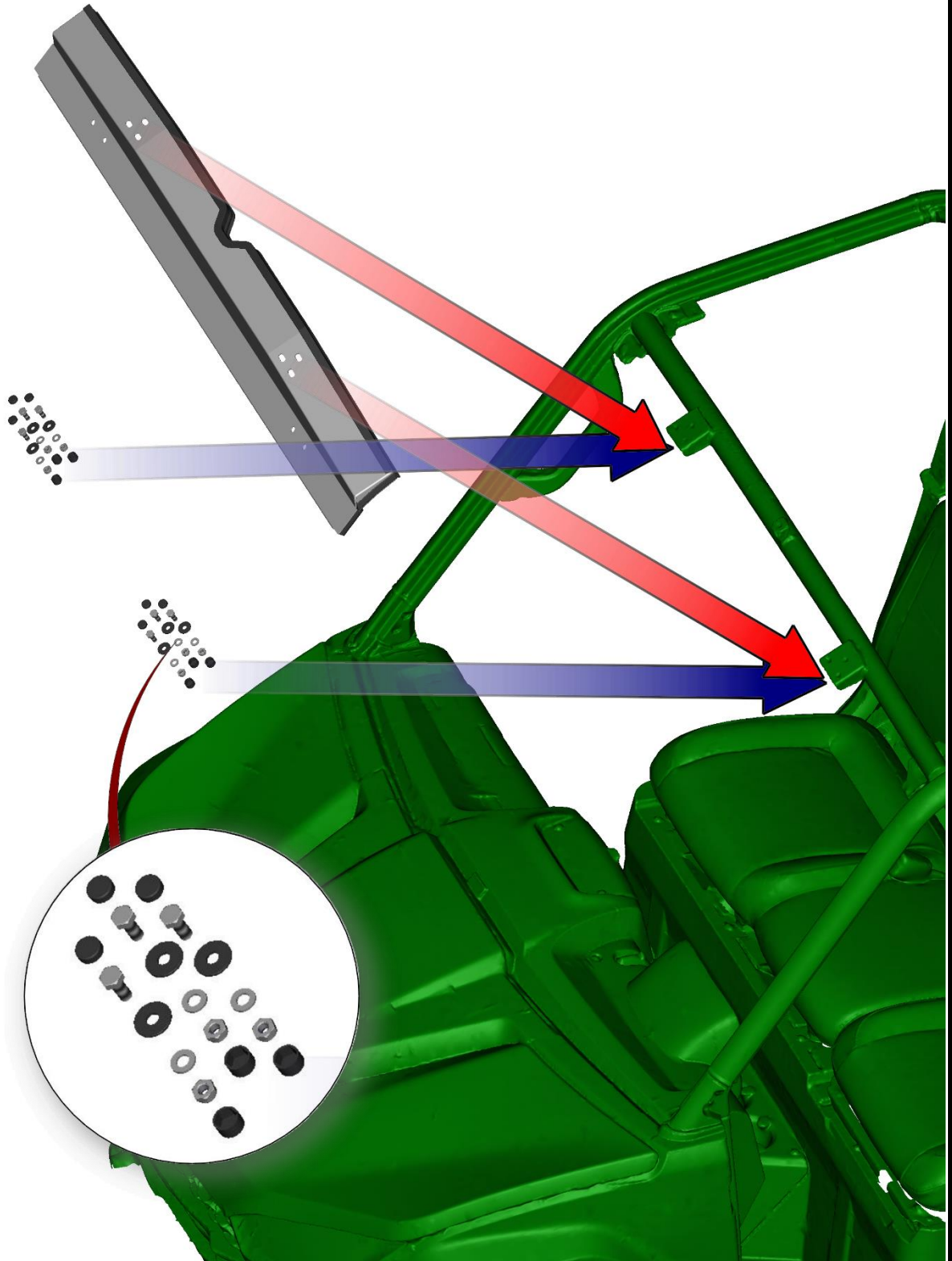

33

Loose the side holder screws.

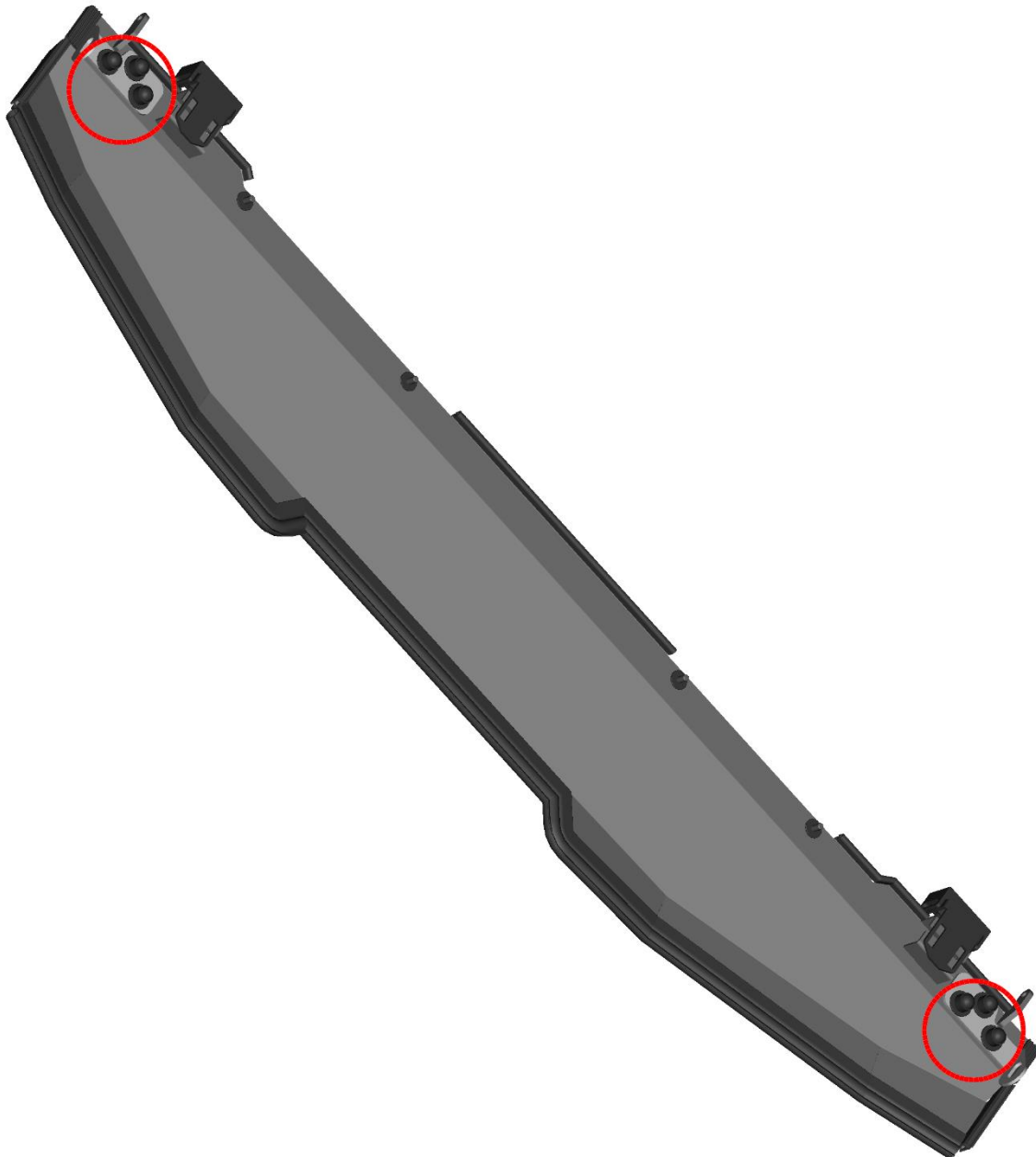

34

Uninstall the bottom original screw from both sides.



35

Install the gas spring pins onto the bottom ledge. It is strongly recommended to install it in same directions like on picture.

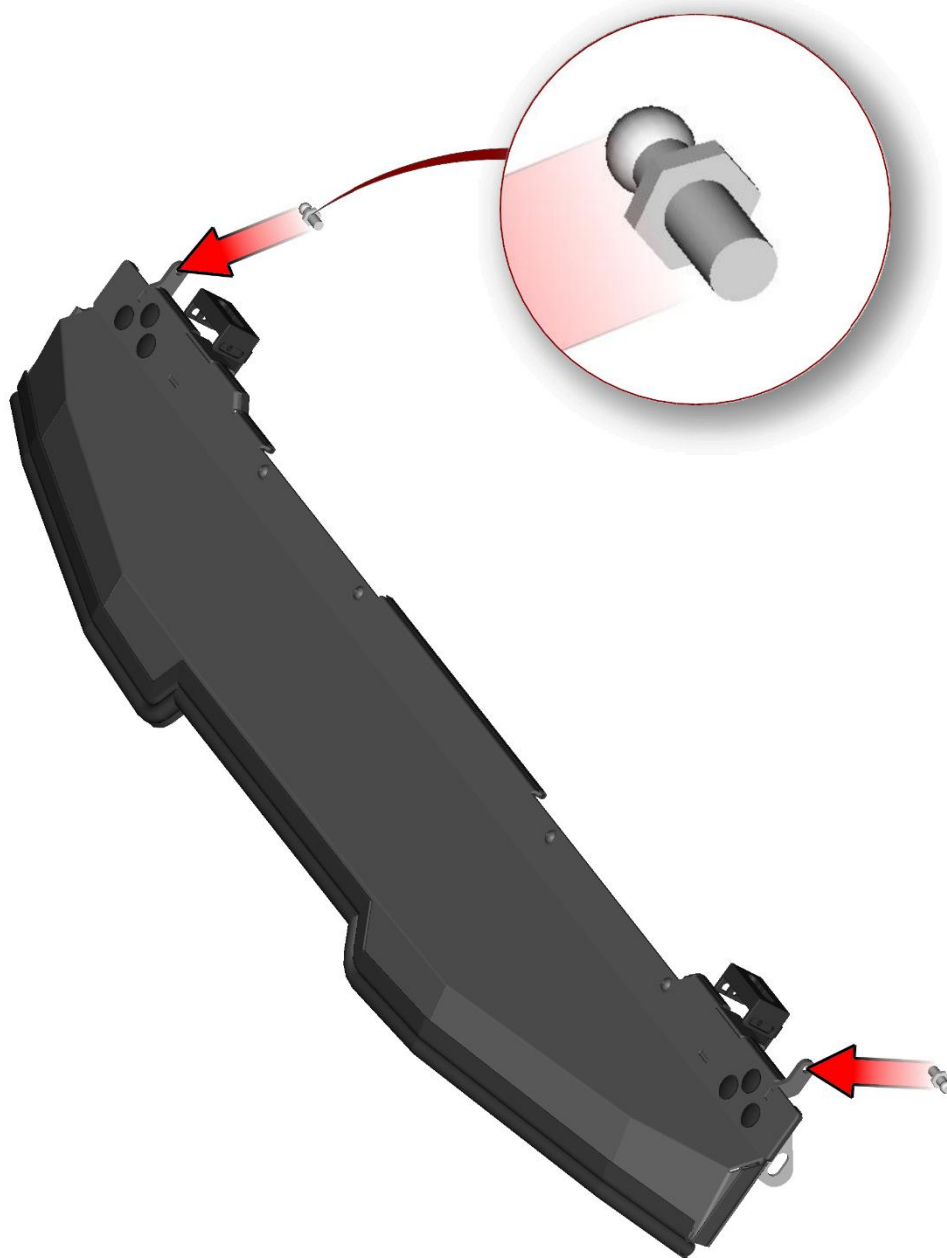

36

Place the front bottom ledge onto the vehicle frame.

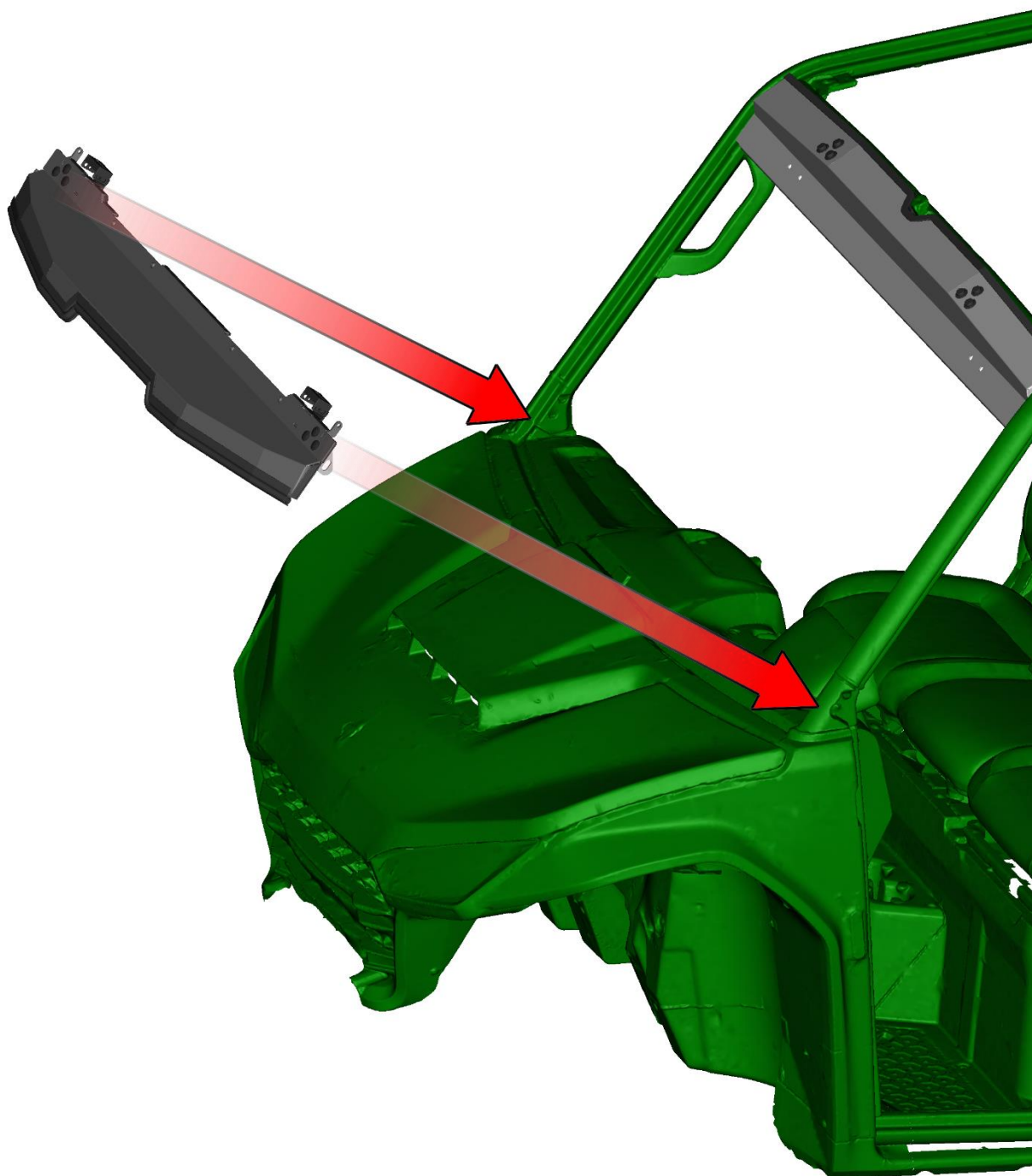

37

Uninstall original screw from the vehicle body.

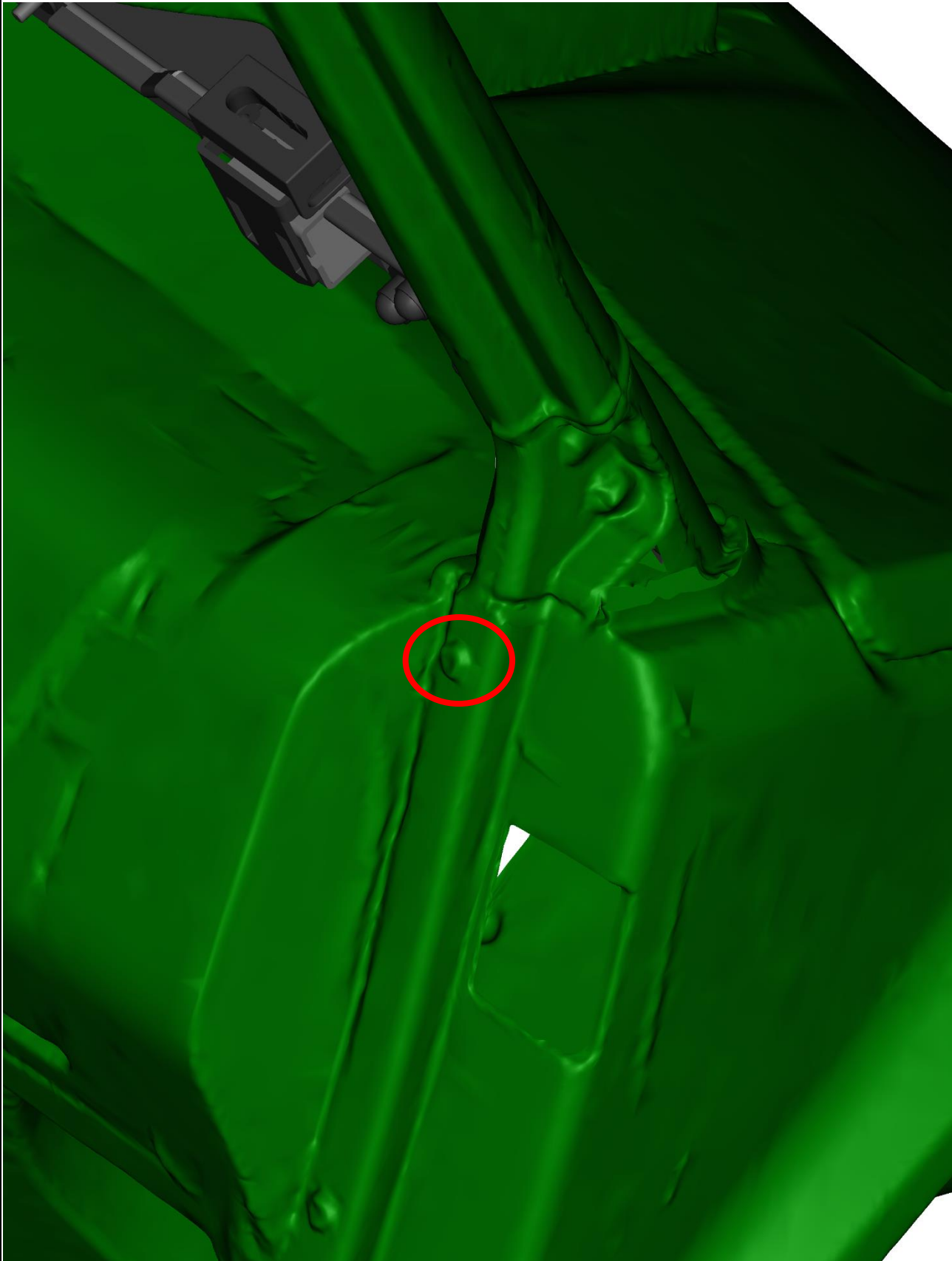

Insert the door stop base between the side holder and frame.

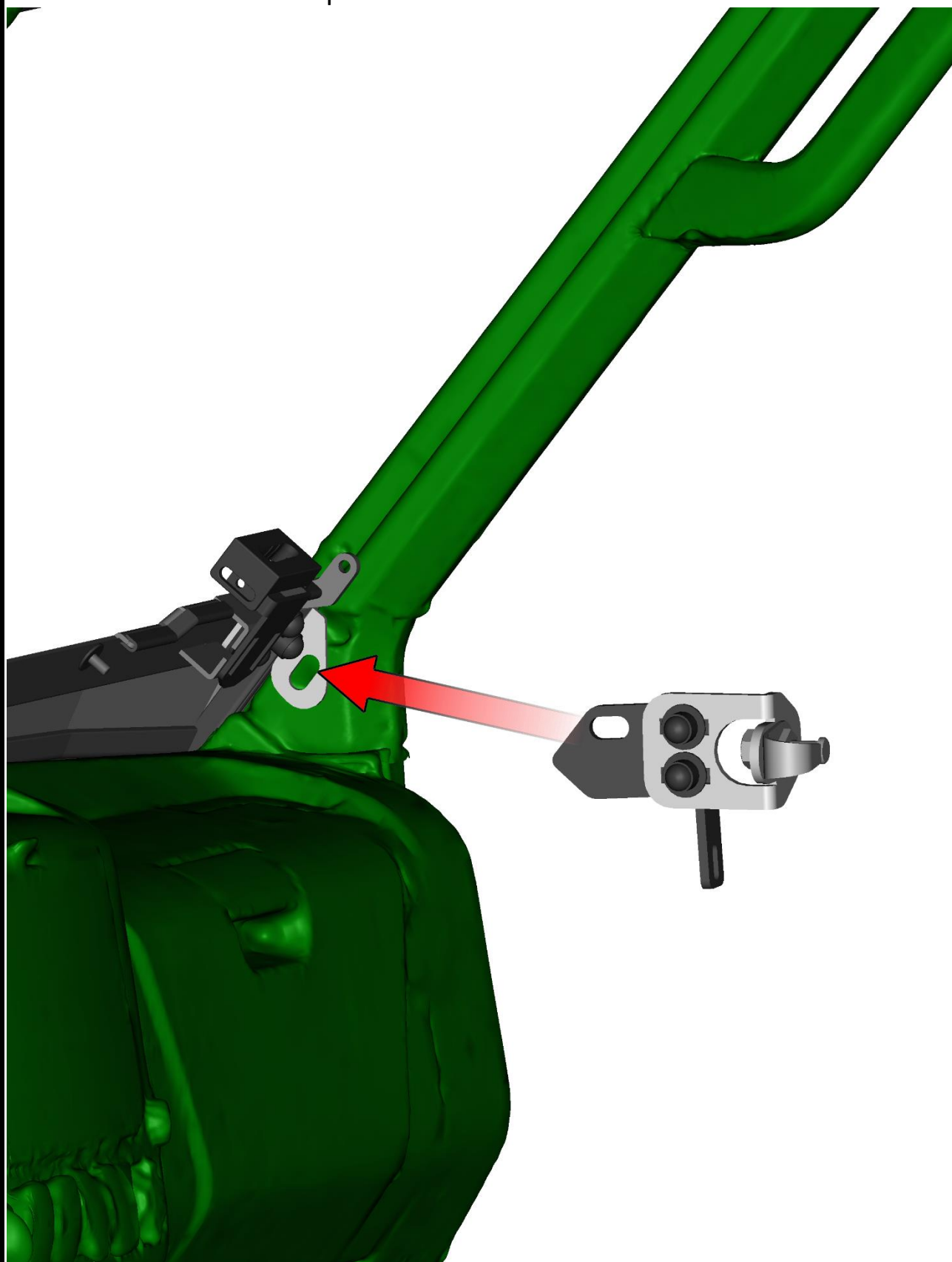

39

Fix the holder with the base to the frame
by included screw, washer, nut and cover.

40

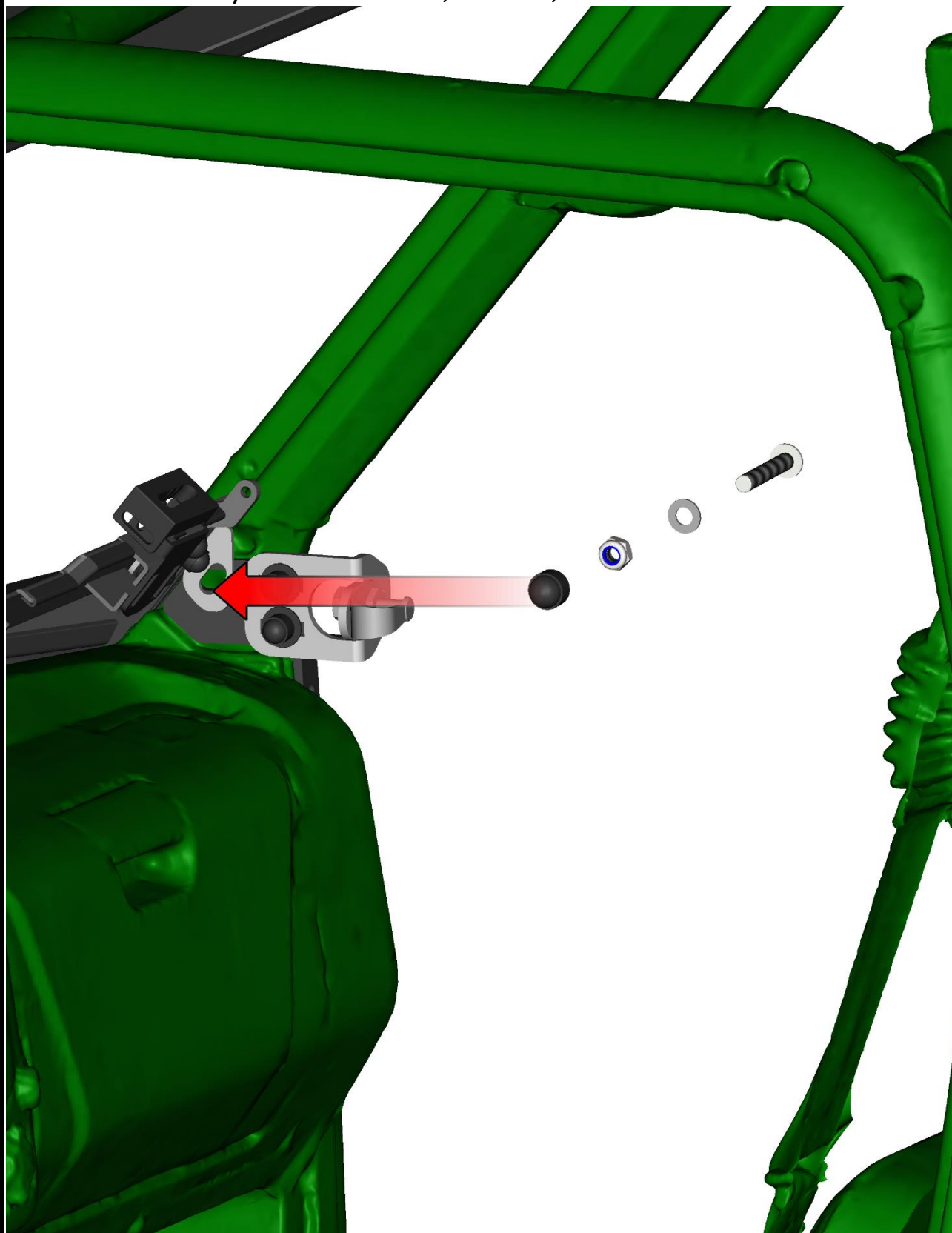

Secure the holder with the vehicle by original screw.

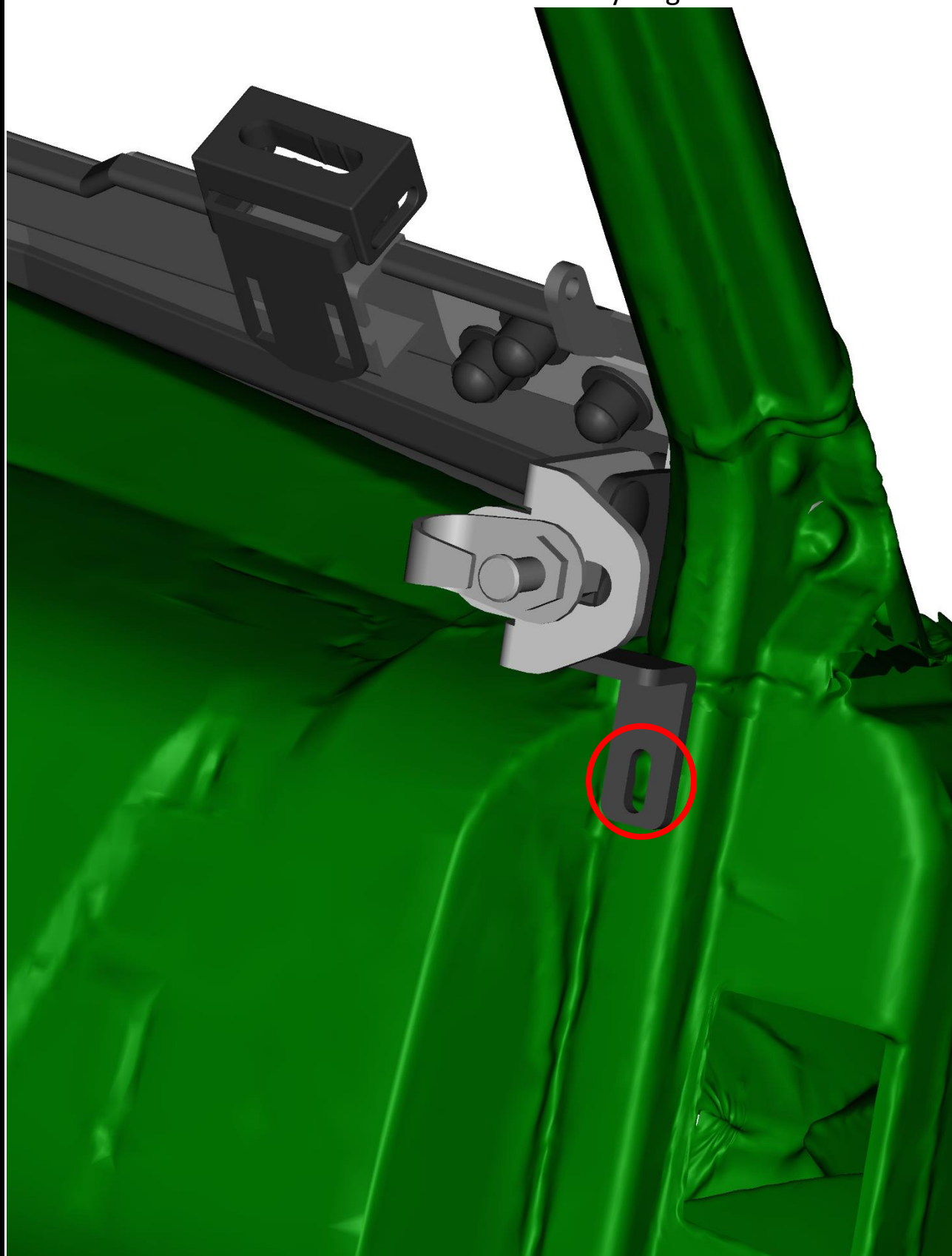

41

Place the window with the hinge bases onto the front ledge.
Fix the hinge with the base to the ledge
by included screws, washers, nuts and covers.

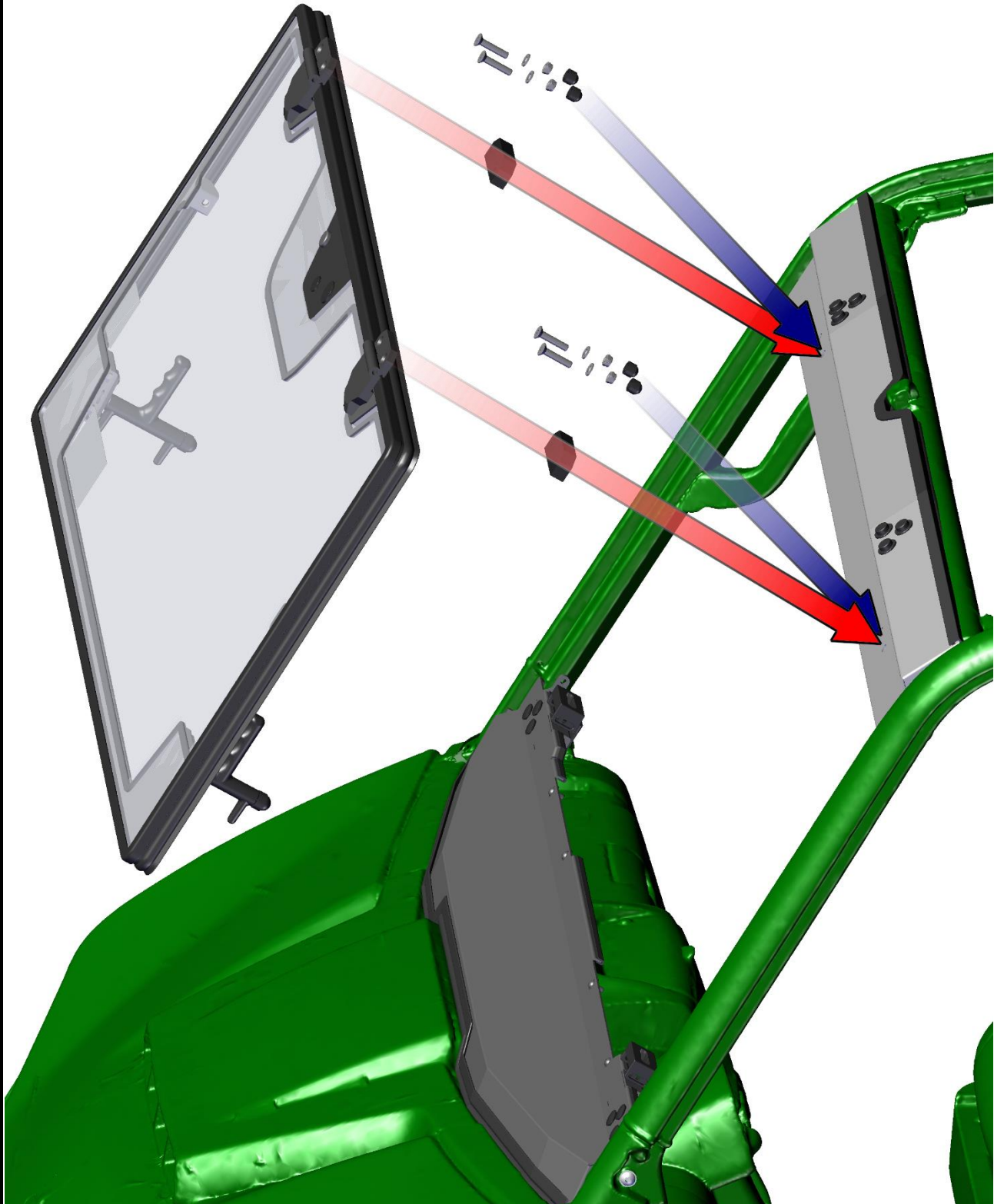

42

Install front gas spring into the holders on both sides. **It is very important to install gas spring in same orientation like on picture.**

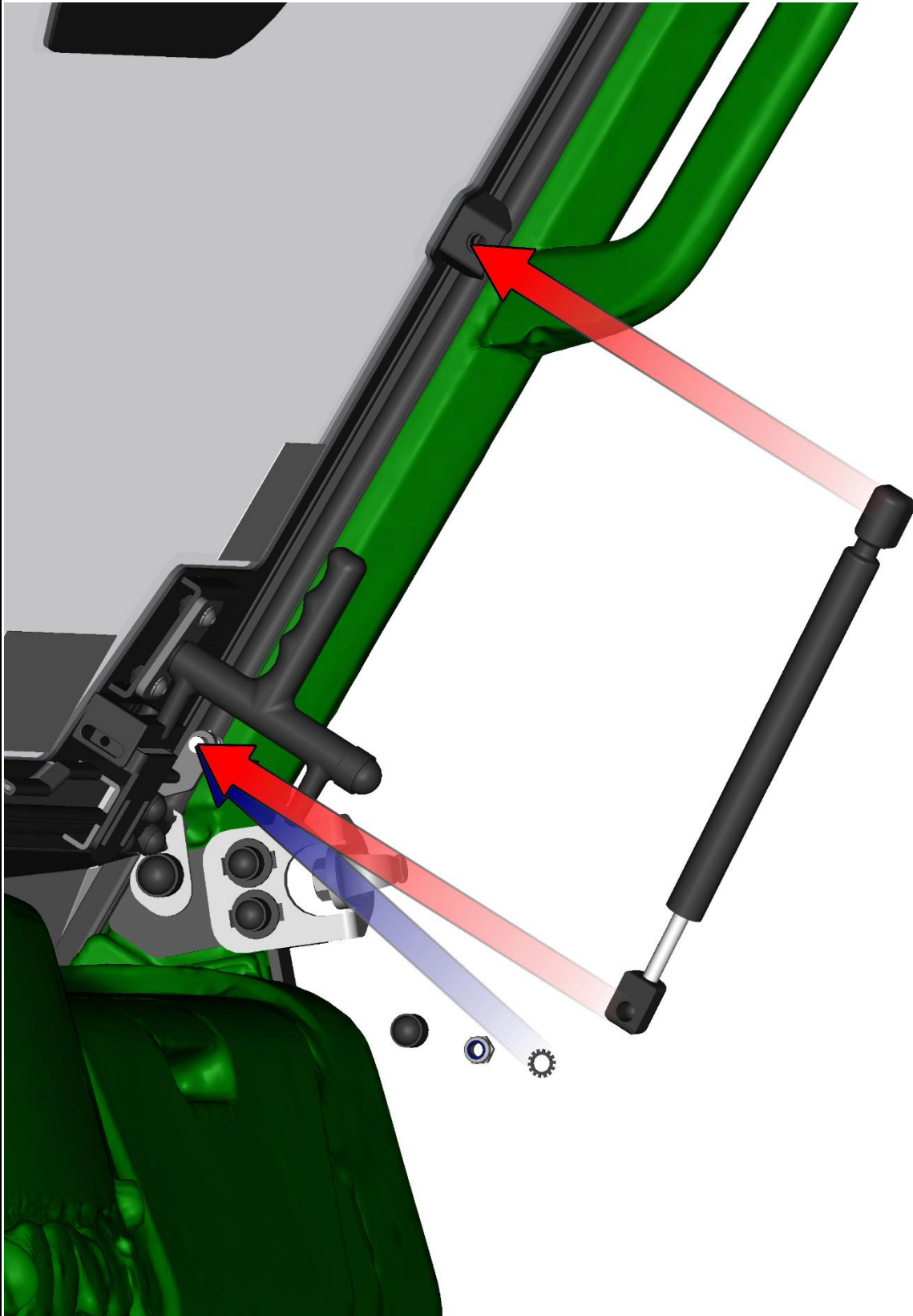

43

Adjust the glass stop assembly to the best position for glass lock on both sides.

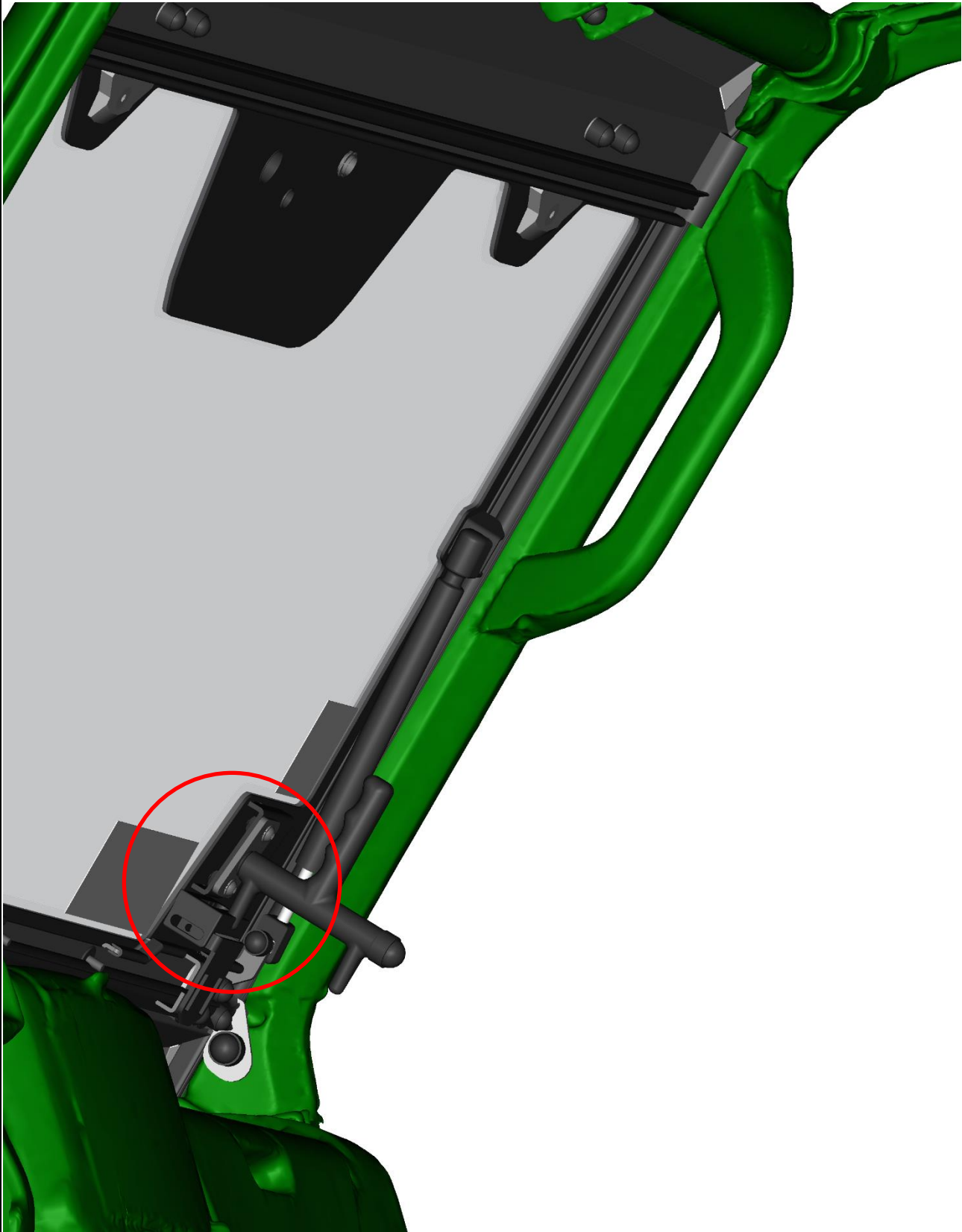

44

Tighten all screws and nuts correctly.

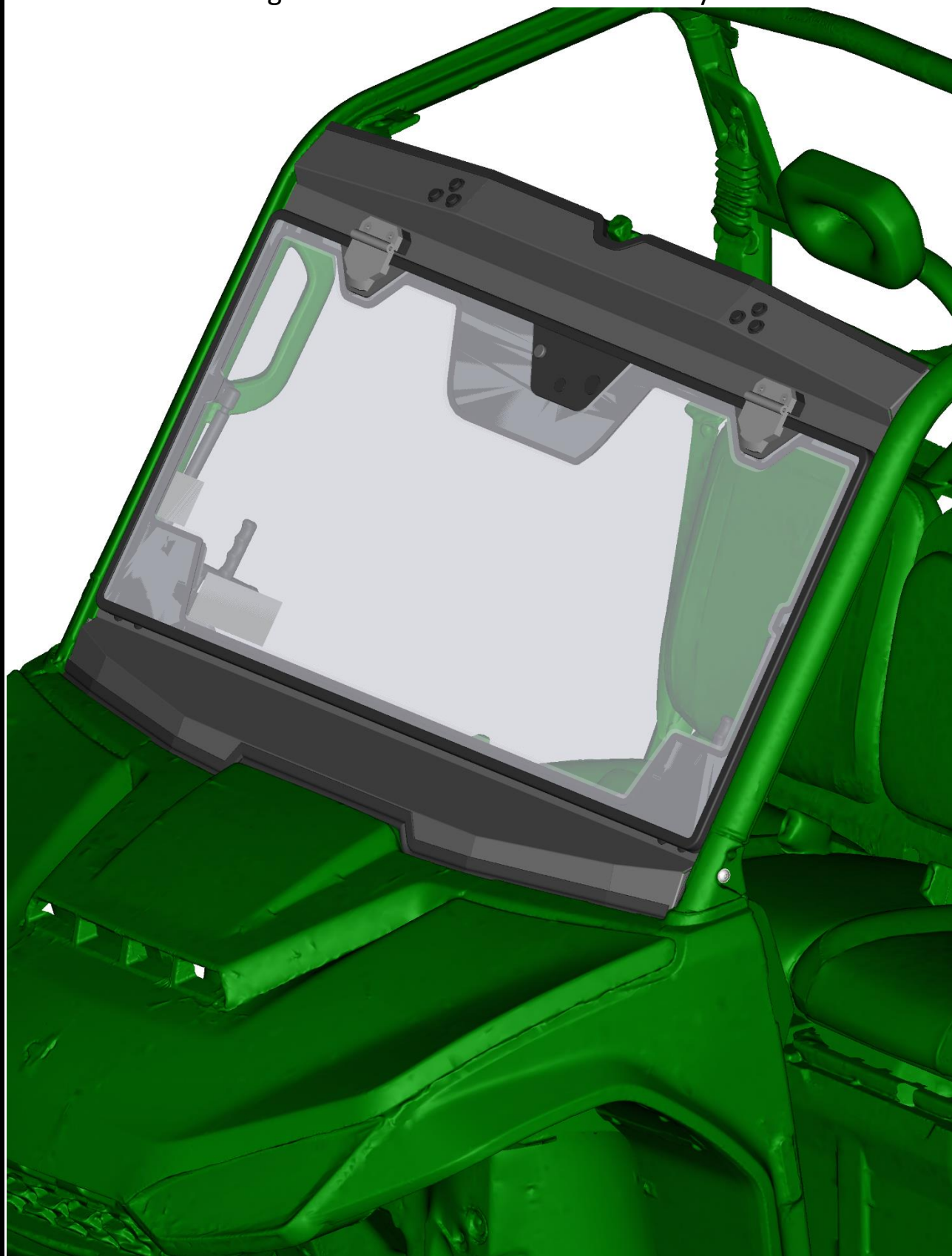

45

ROOF 1.

Place the roof onto the vehicle frame.

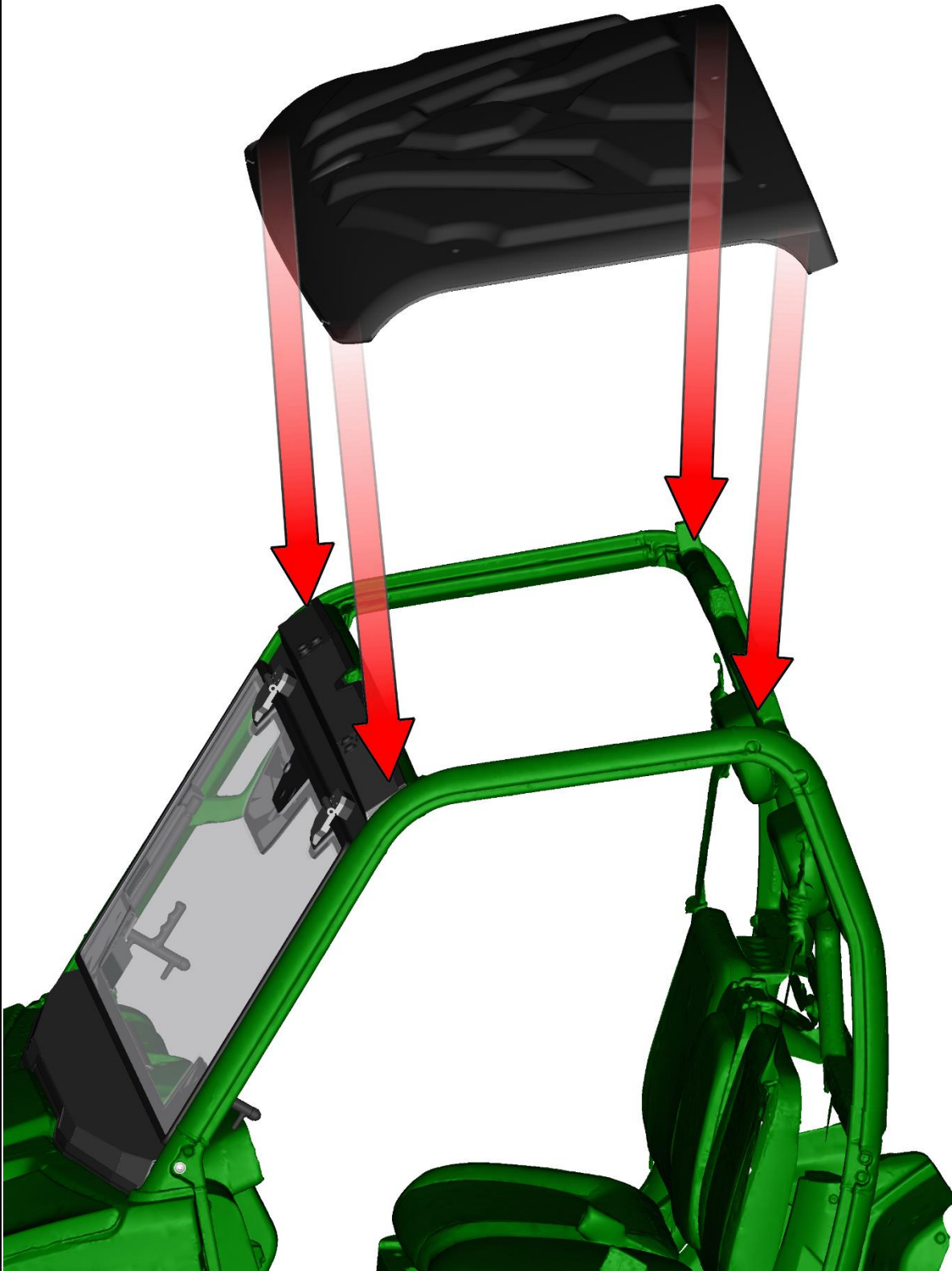

46

Push the roof to the front side.

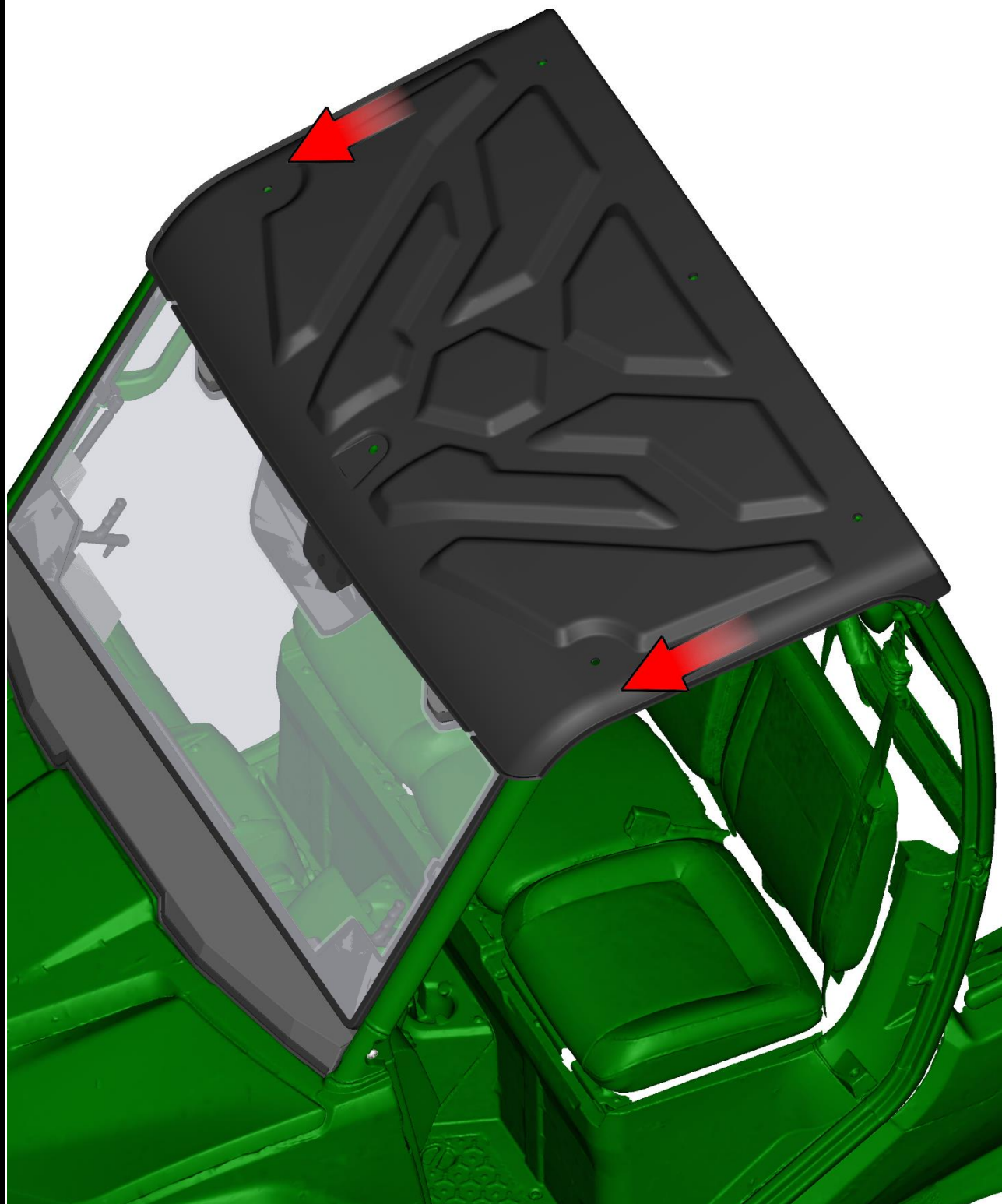

47

REAR PANEL

Loose the holder screws and turn the holders to the neutral position.

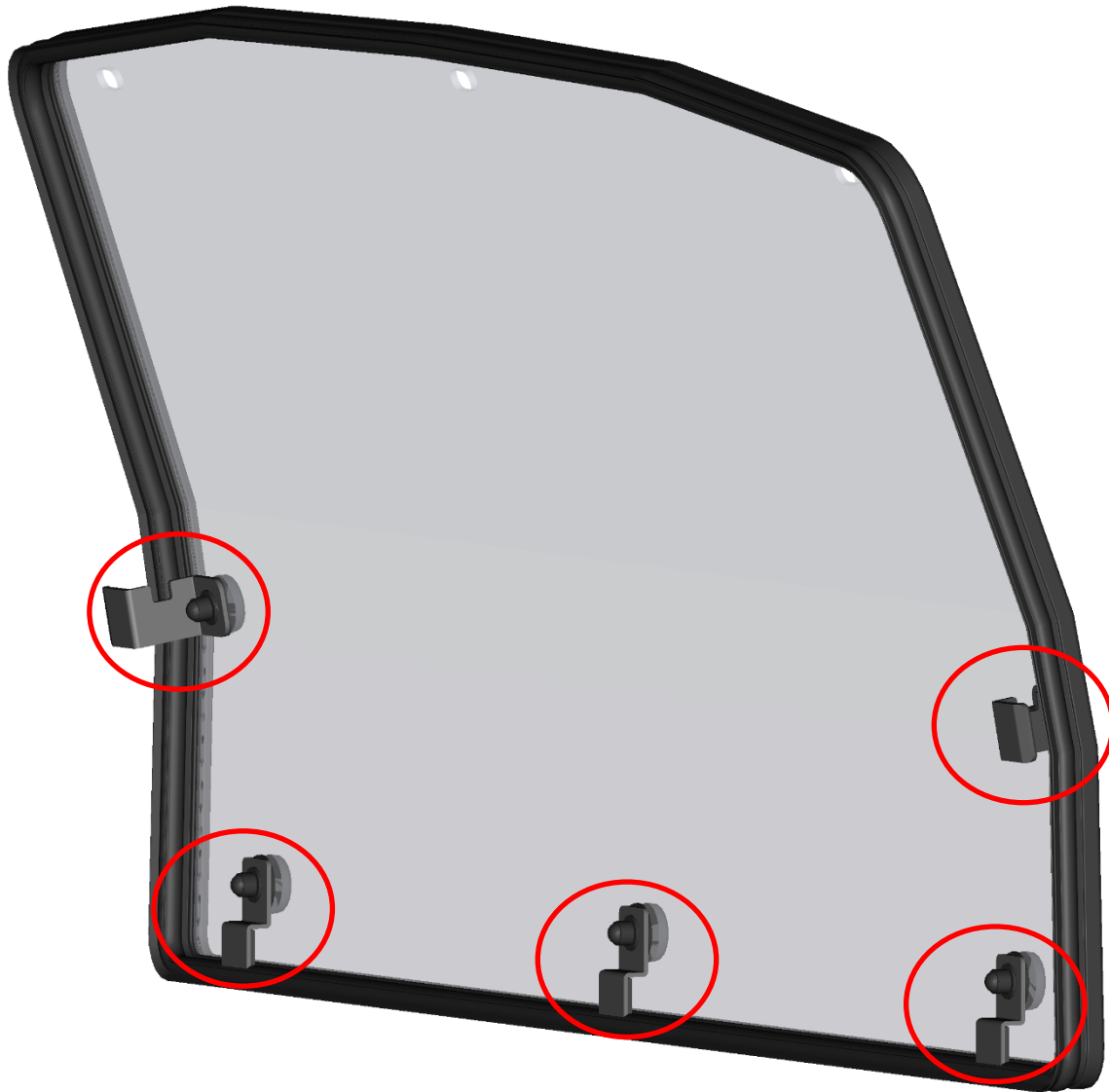

48

Place the rear panel onto the roof and onto the vehicle frame.

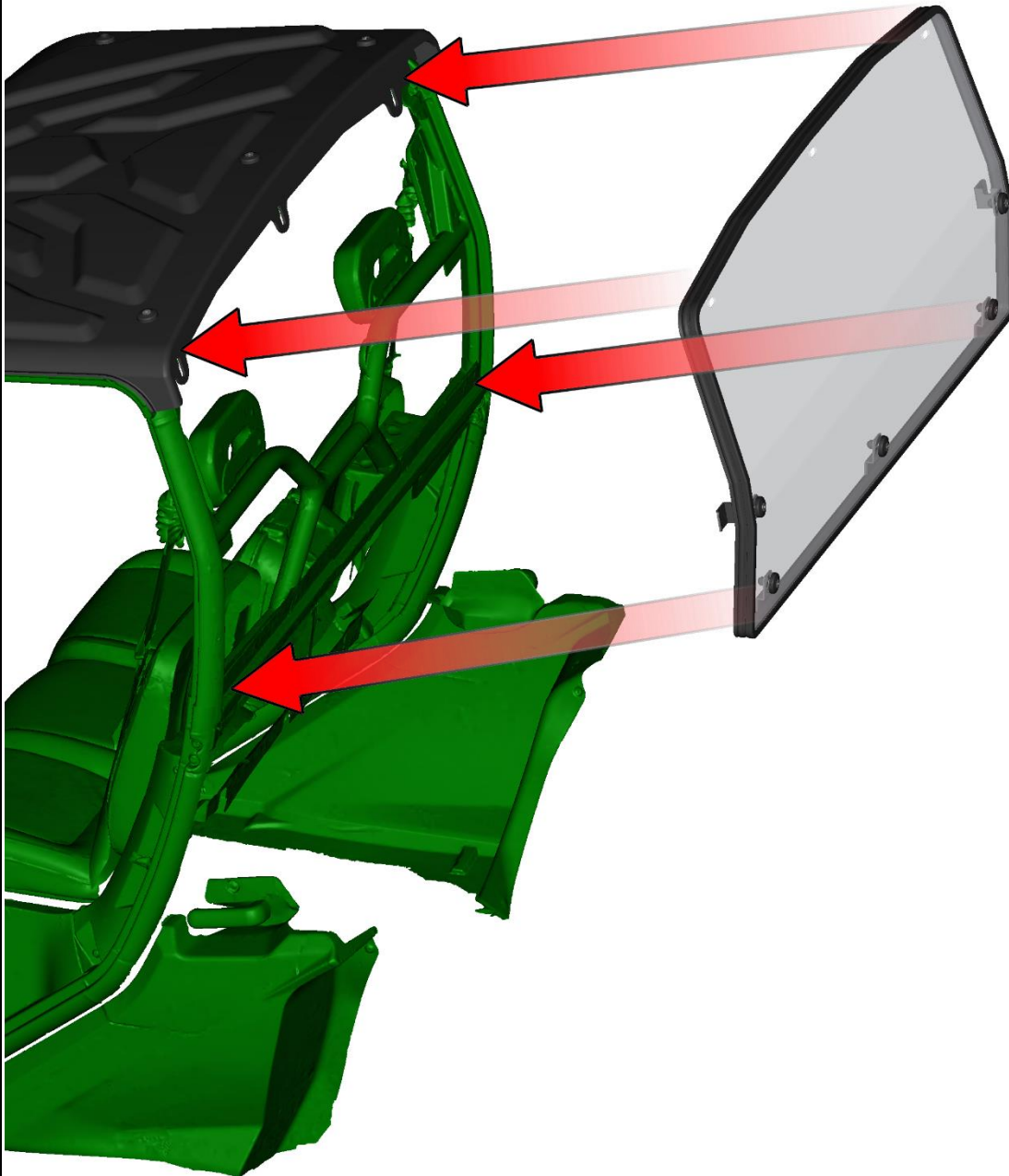

49

Fix the rear poly with the roof by included screws, washers, distance tubes, nuts and covers. SEE NEXT PAGE

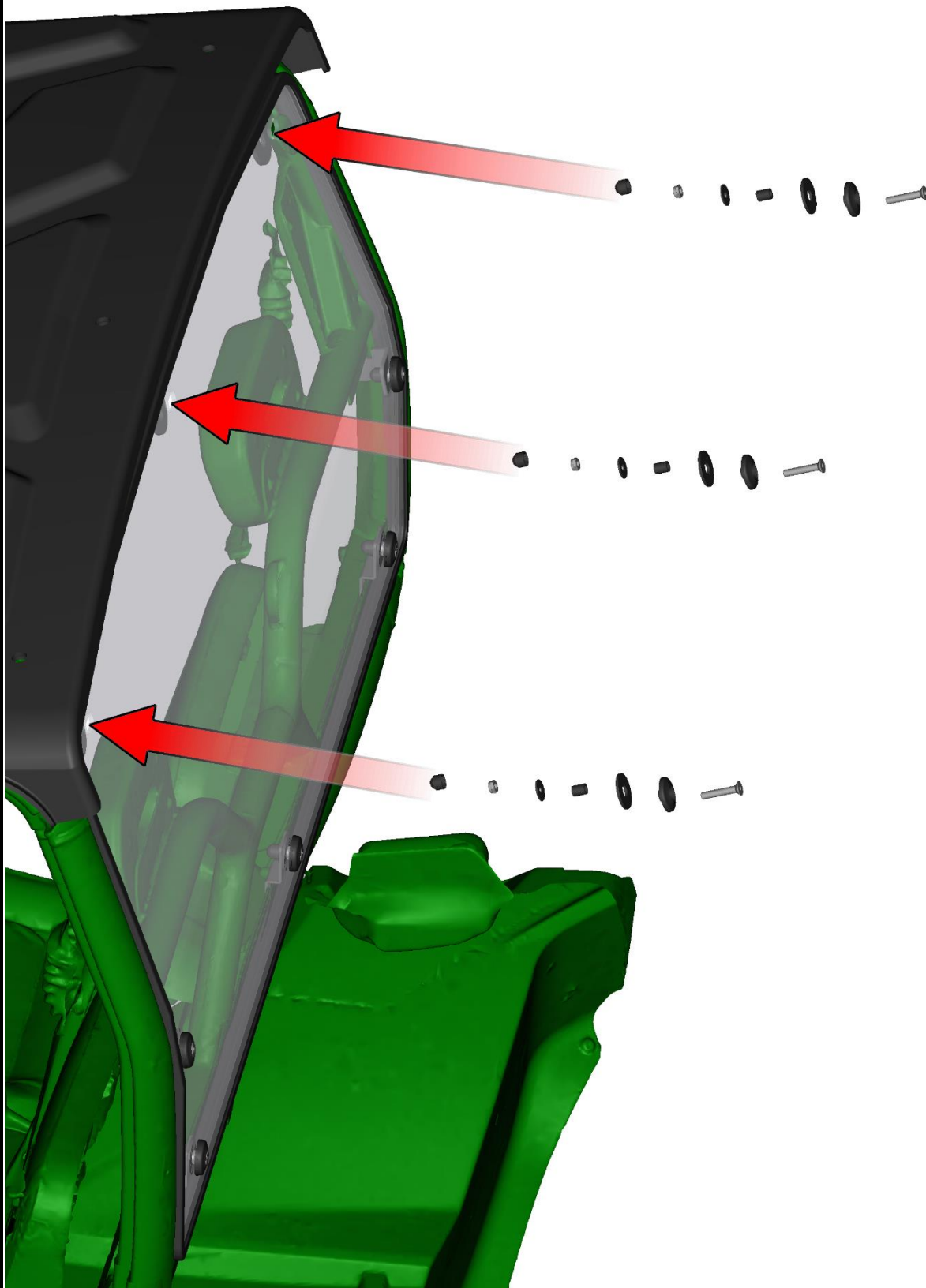

50

CUTTING VIEW OF THE CONNECTION

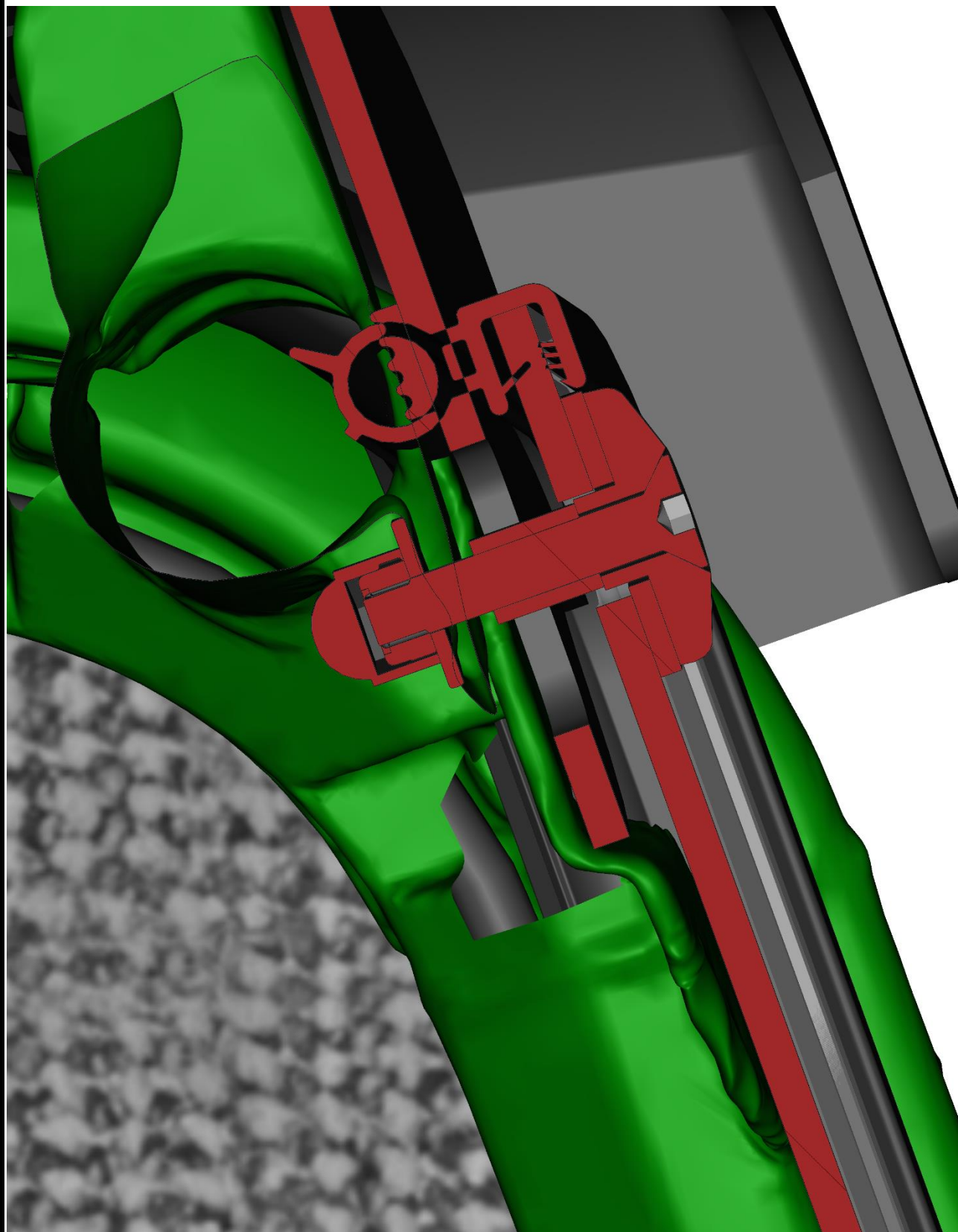

51

Turn the holders to the correct position and tighten screws easy.

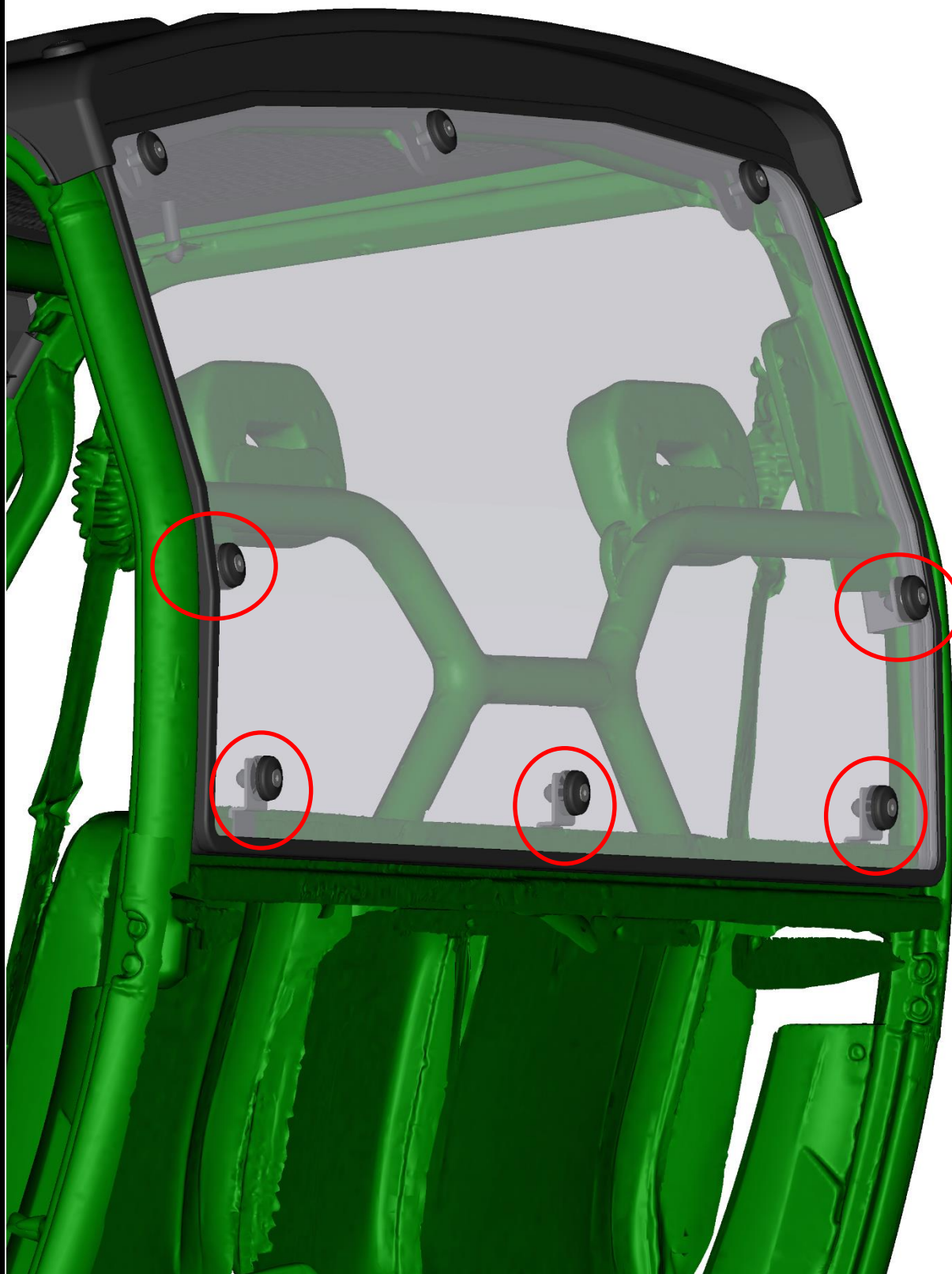

ROOF 2.

Fix the roof with the frame by included screw and washers.

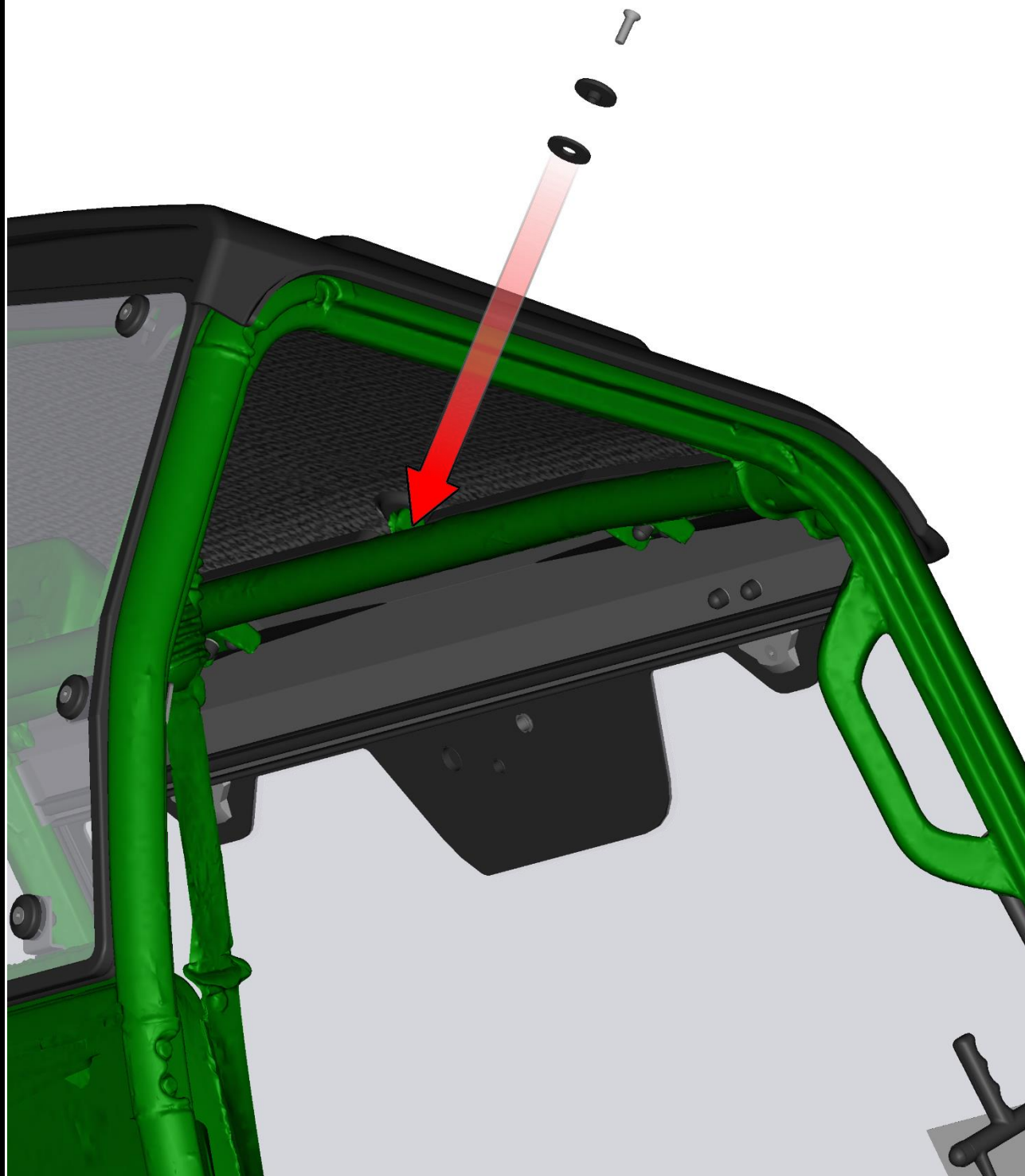

53

Fix the roof with the frame by included screws and washers.

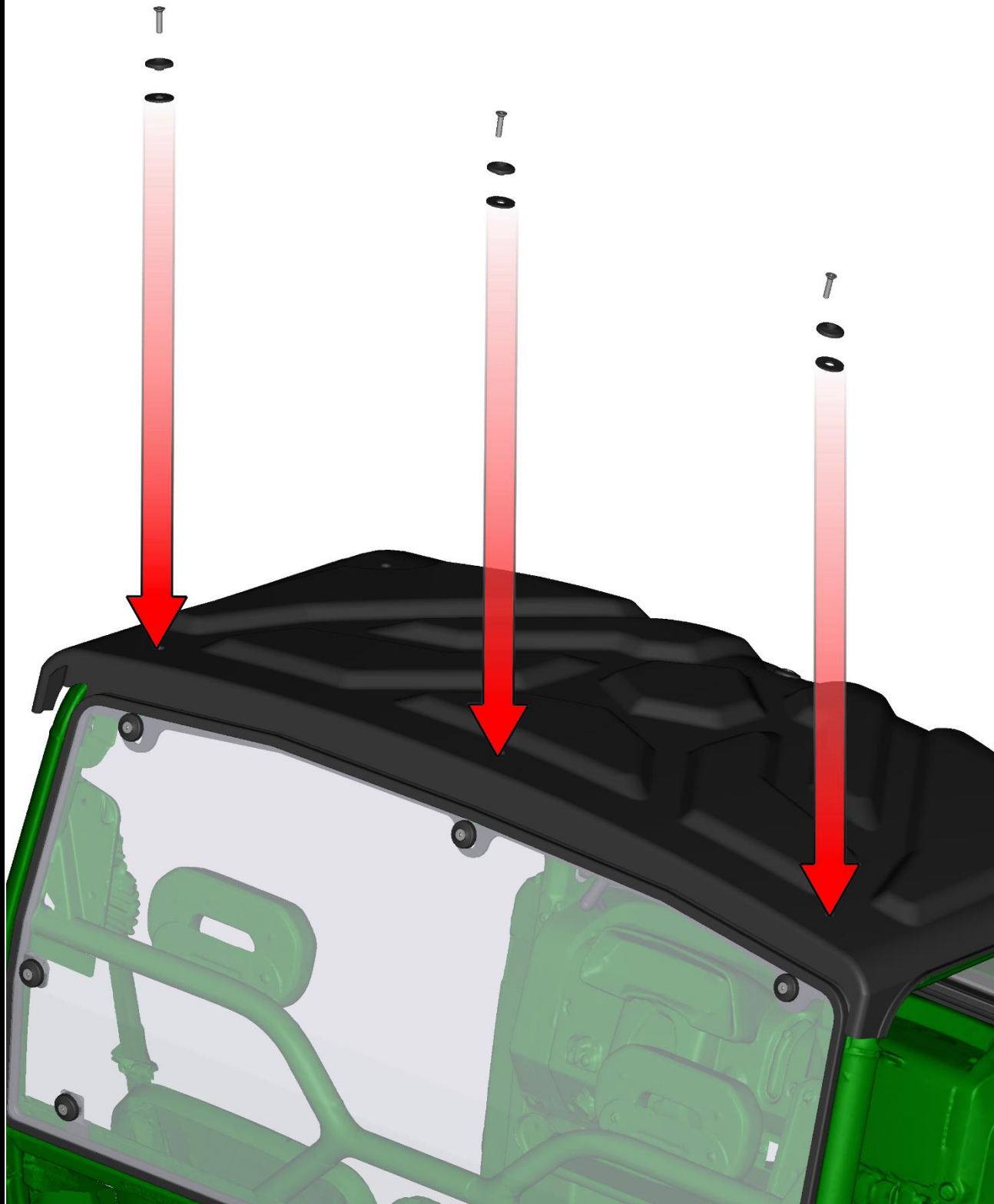

Fix the roof with the frame by included screws, washers, distance tubes, nuts and covers.

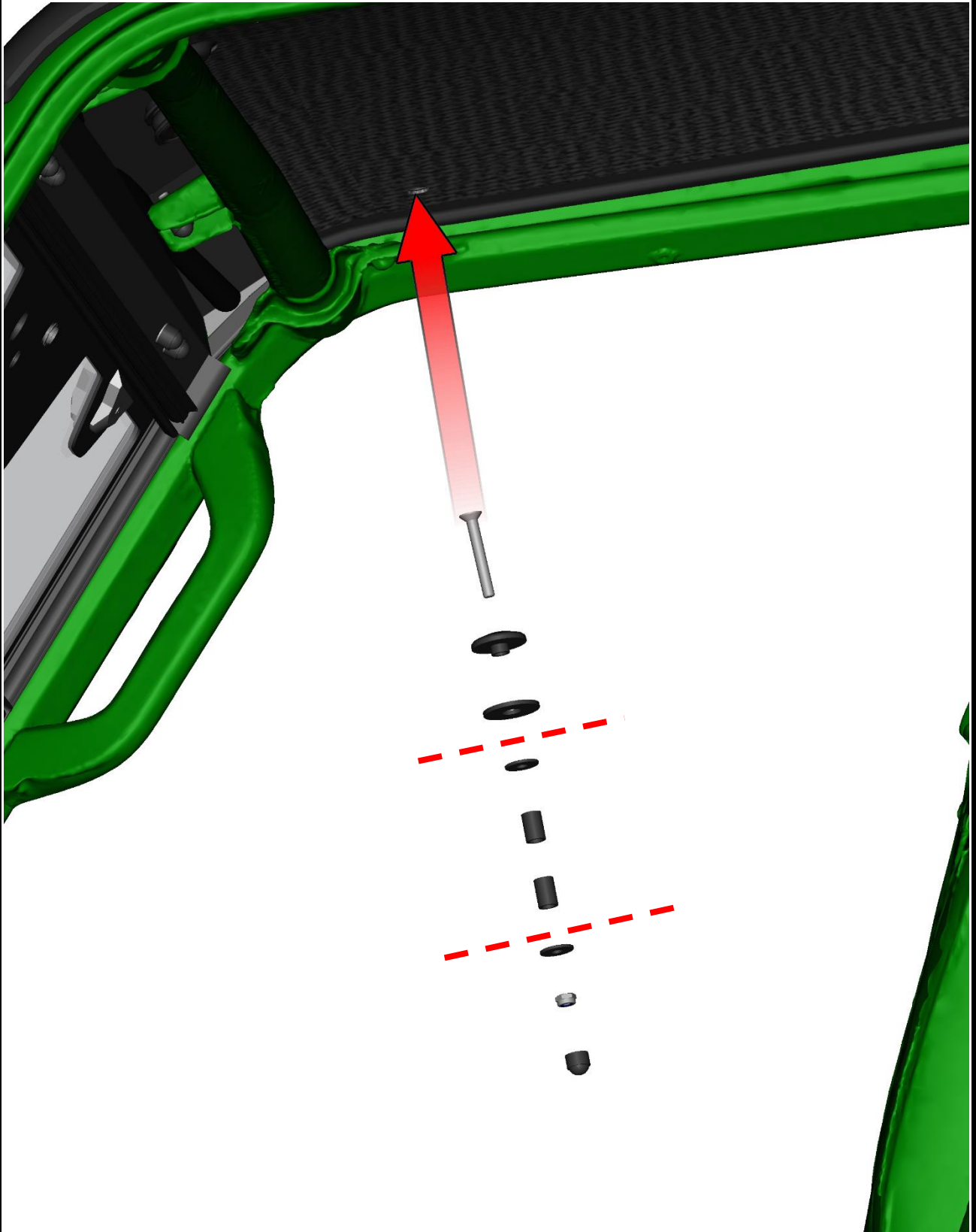

55

Tighten all screws and nuts correctly.



56

LEFT DOOR + RIGHT DOOR

Take out the door base holders, save the holders for later usage.

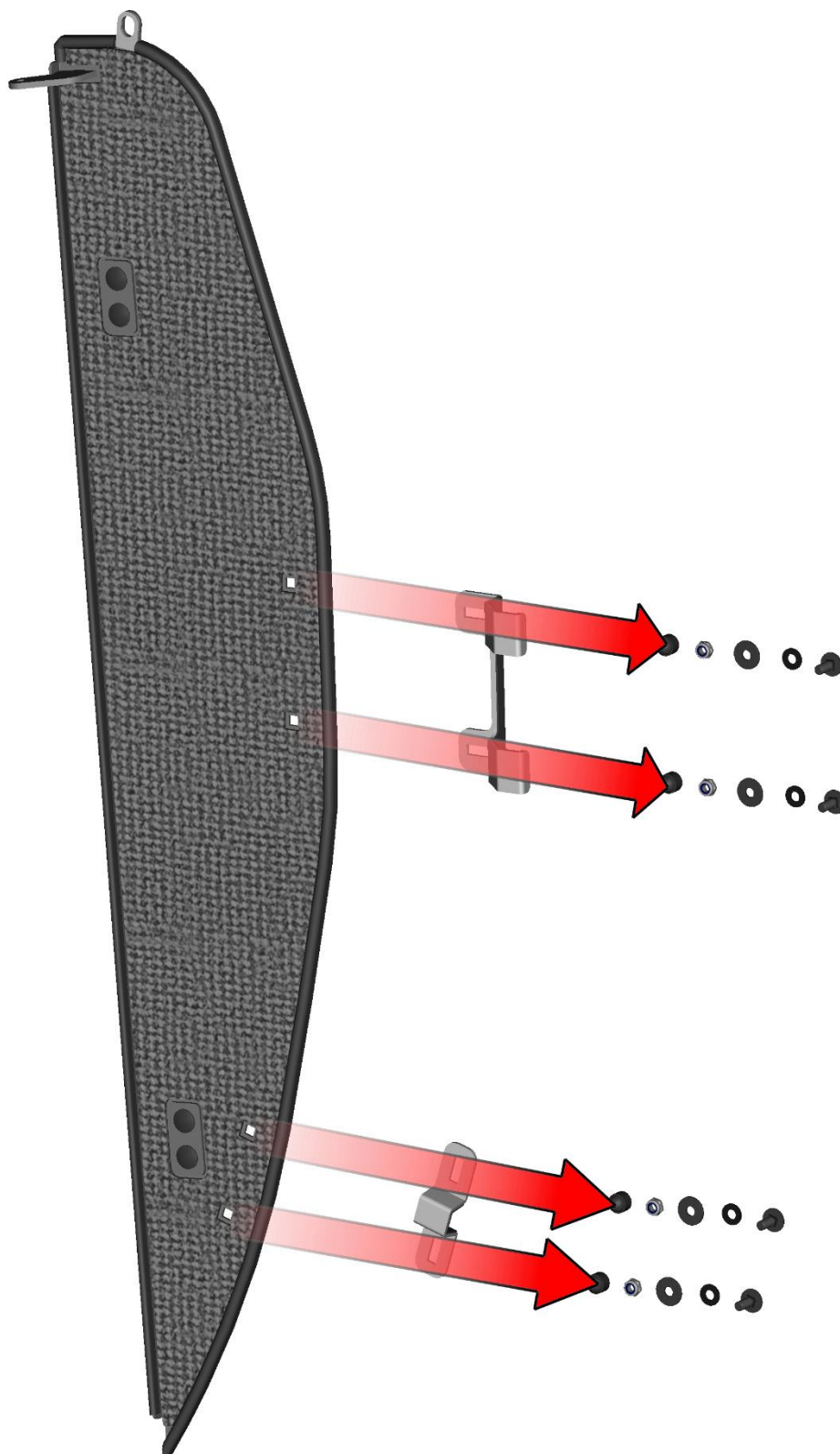

57

Loose the original screw from the vehicle frame.
Save the original screw for later usage.

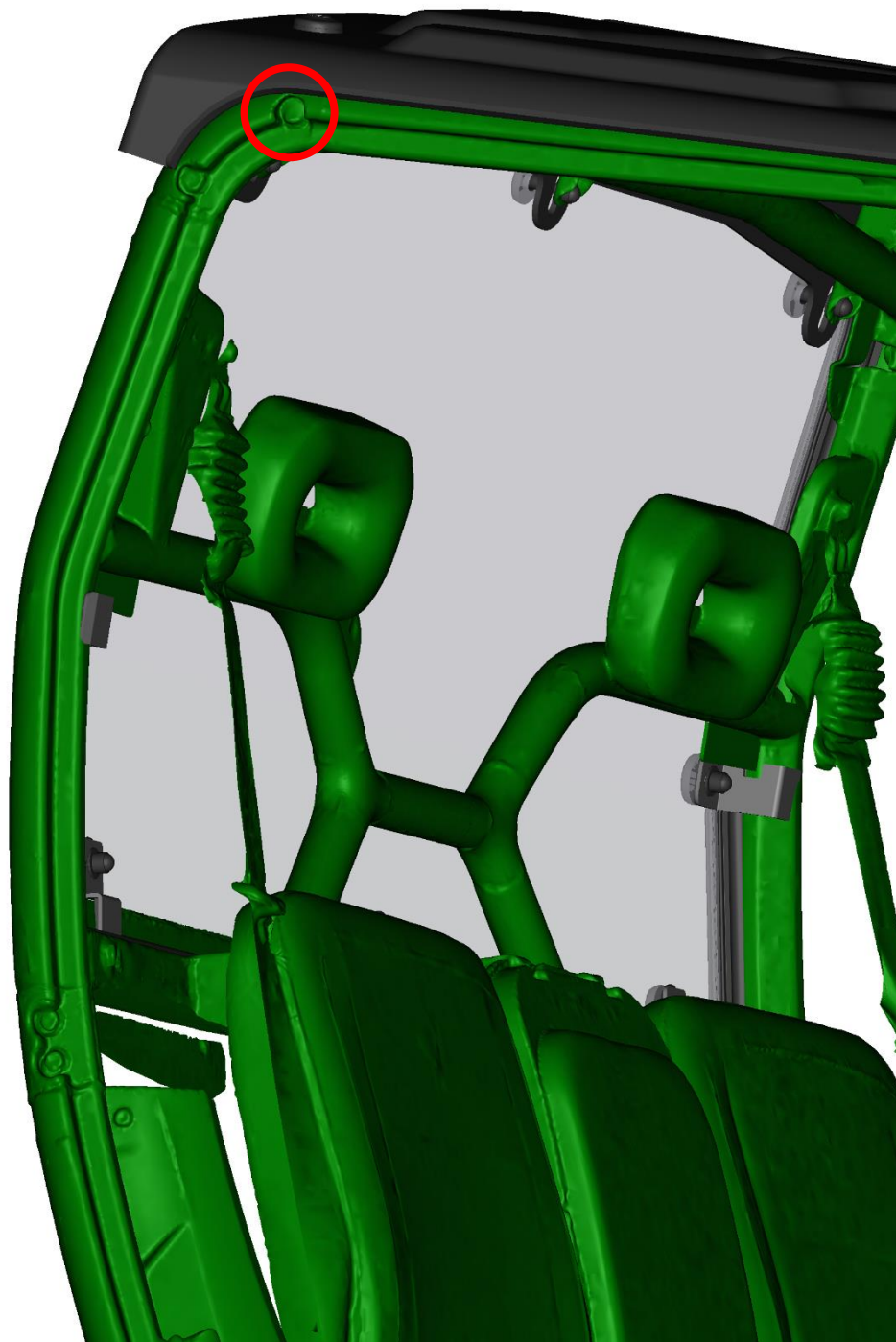

Place the door base onto the vehicle frame.

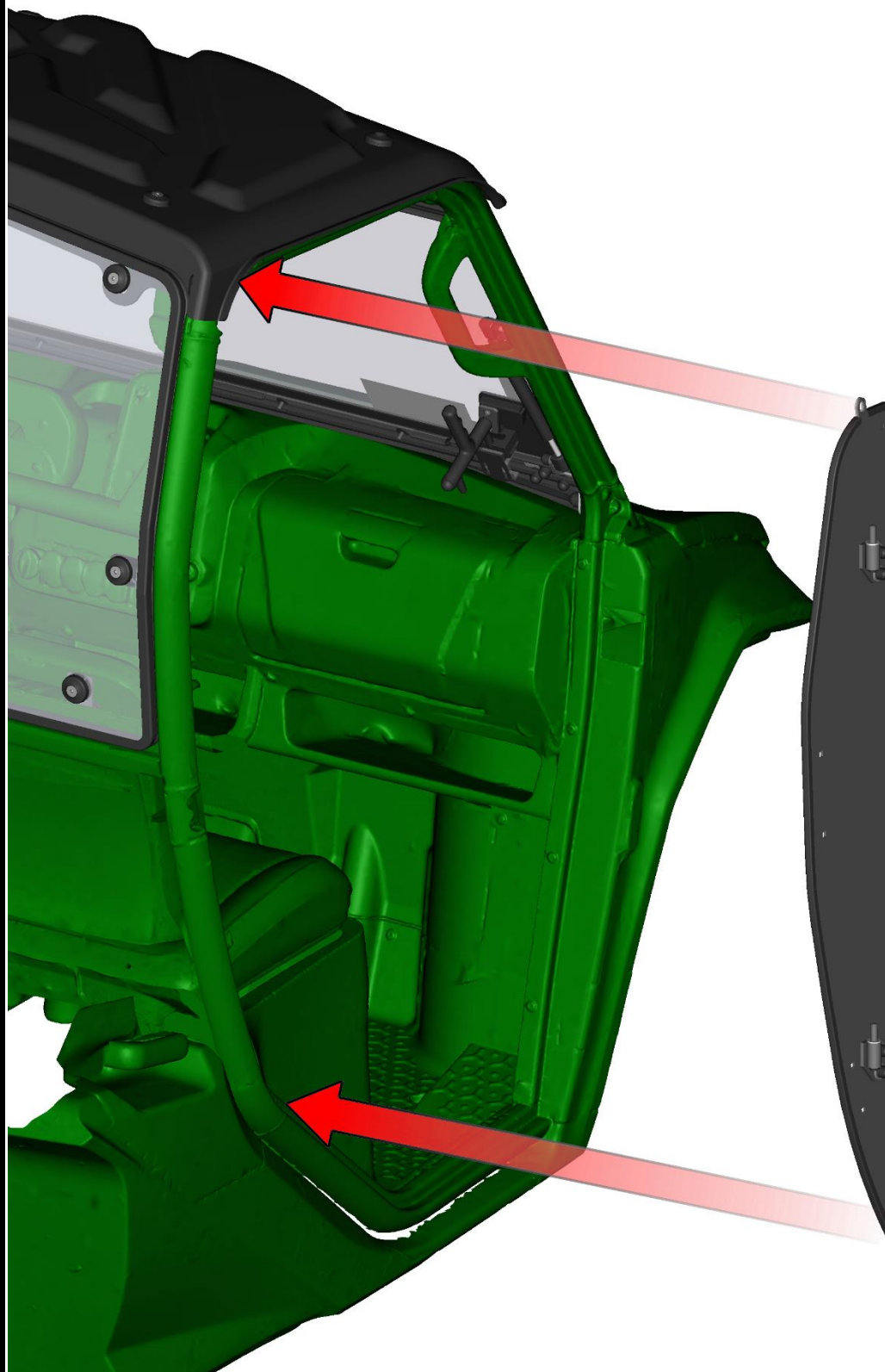

59

Fix the base with the frame by original screw.

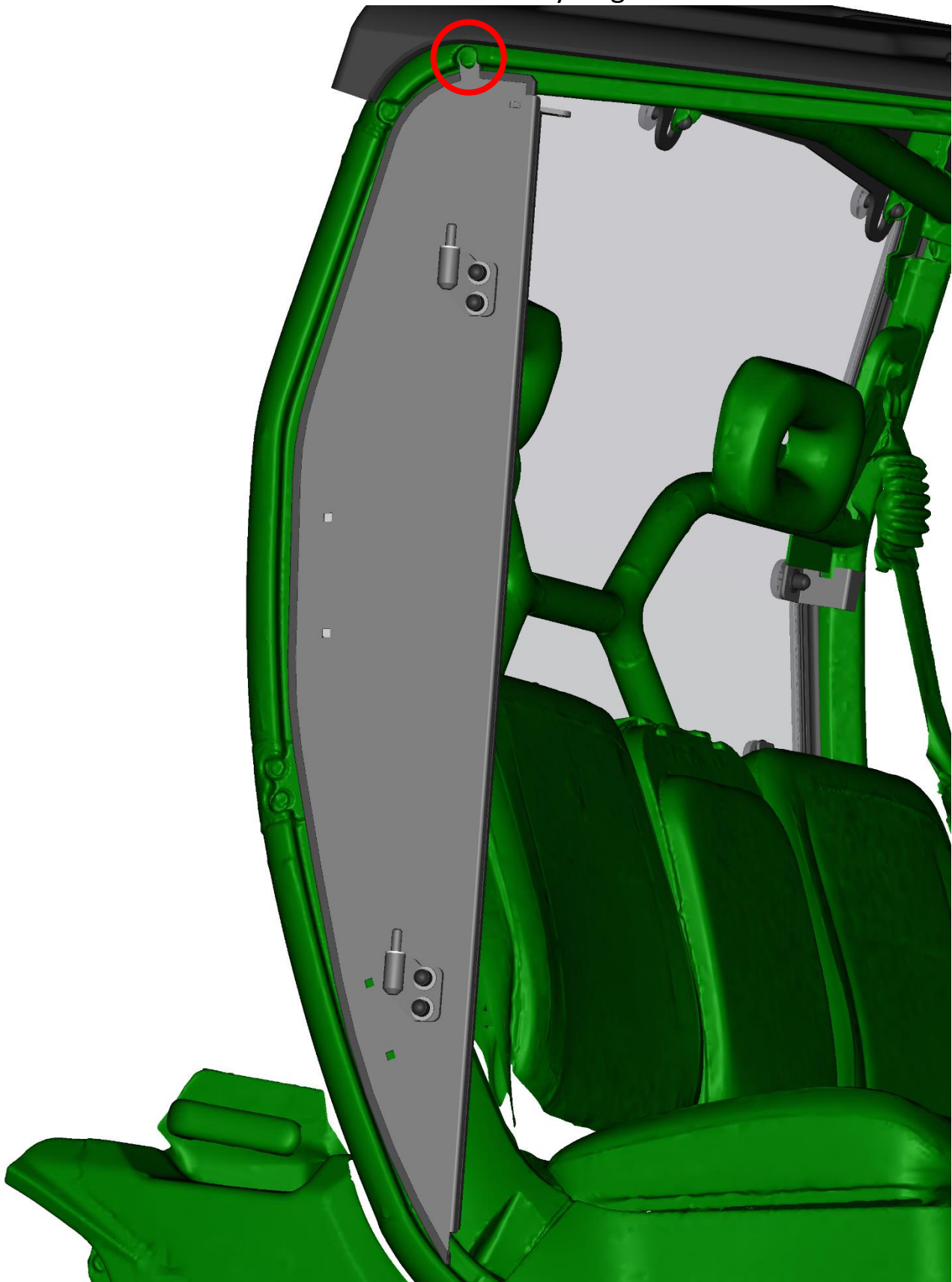

60

Place the door base holders onto the base and onto the frame. Fix the holder with the base by included screws, washers, nuts and covers.

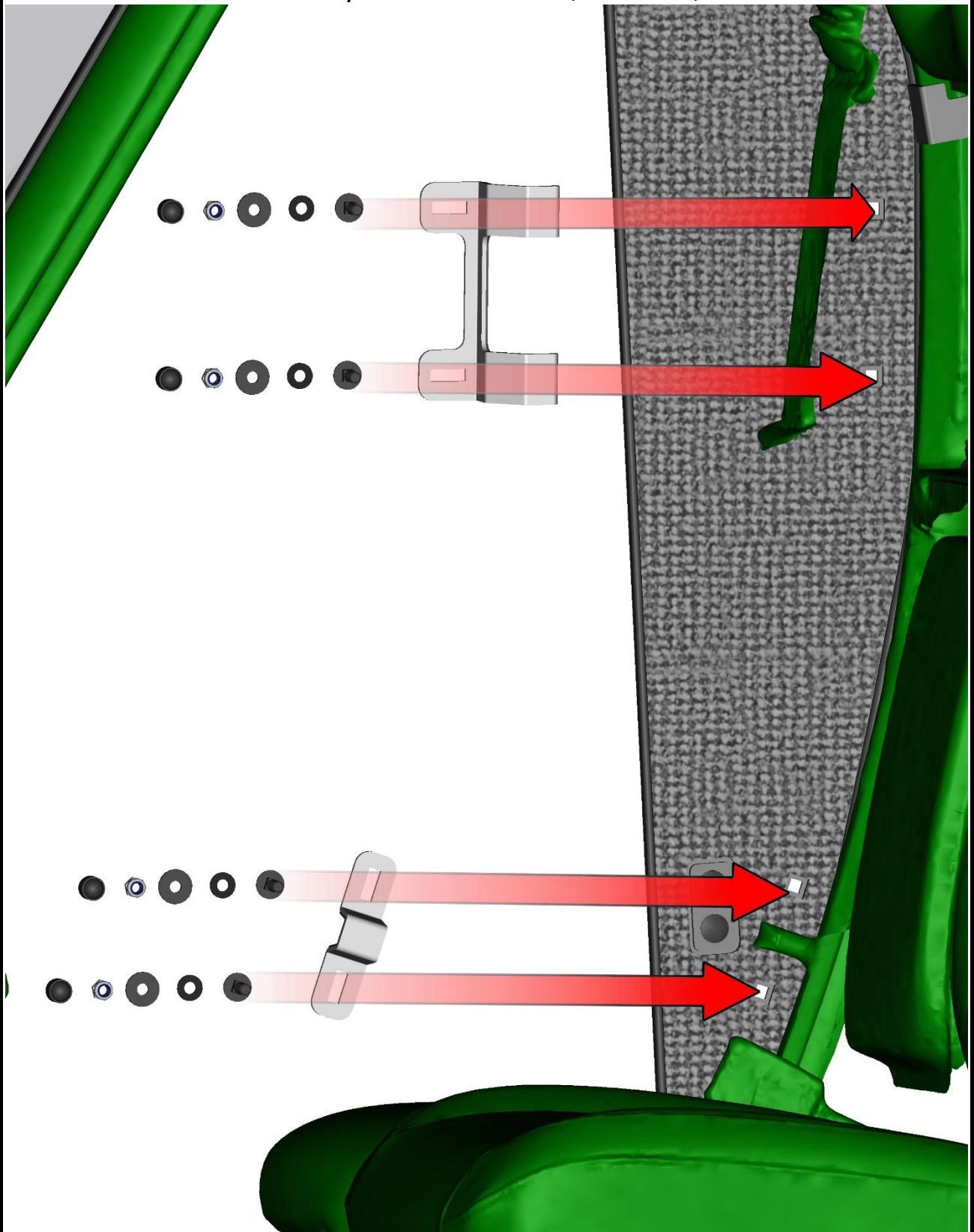

61

Lubricate the hinges pins and place the door onto the hinges.

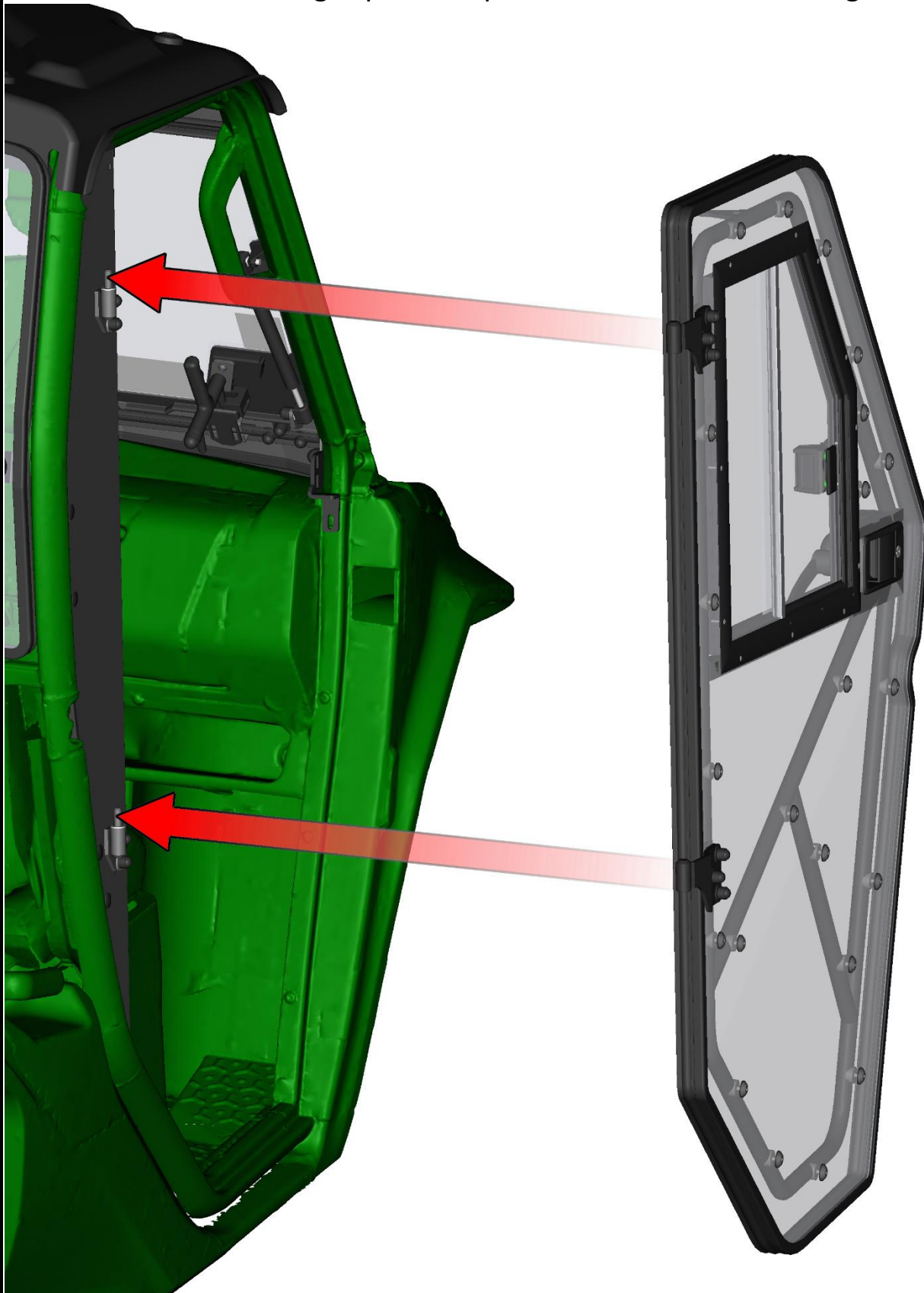

Adjust the door by hinges to the best position.

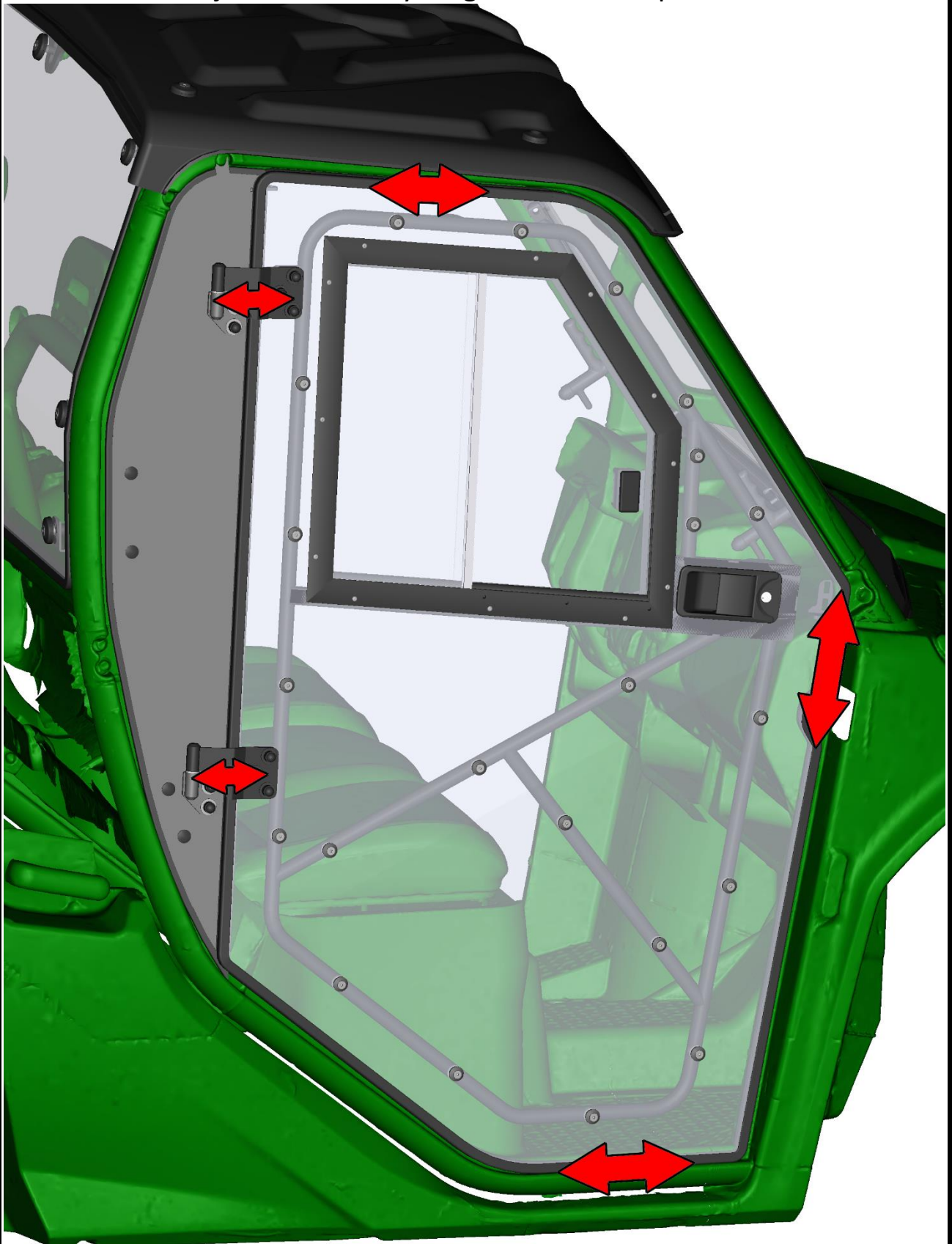

63

Adjust the door stop holder and door stop pin to the best position.
If you adjust the door stop correctly and close the door slowly you can
hear two metallic clicks.



Install gas spring pin onto the gas spring holders.

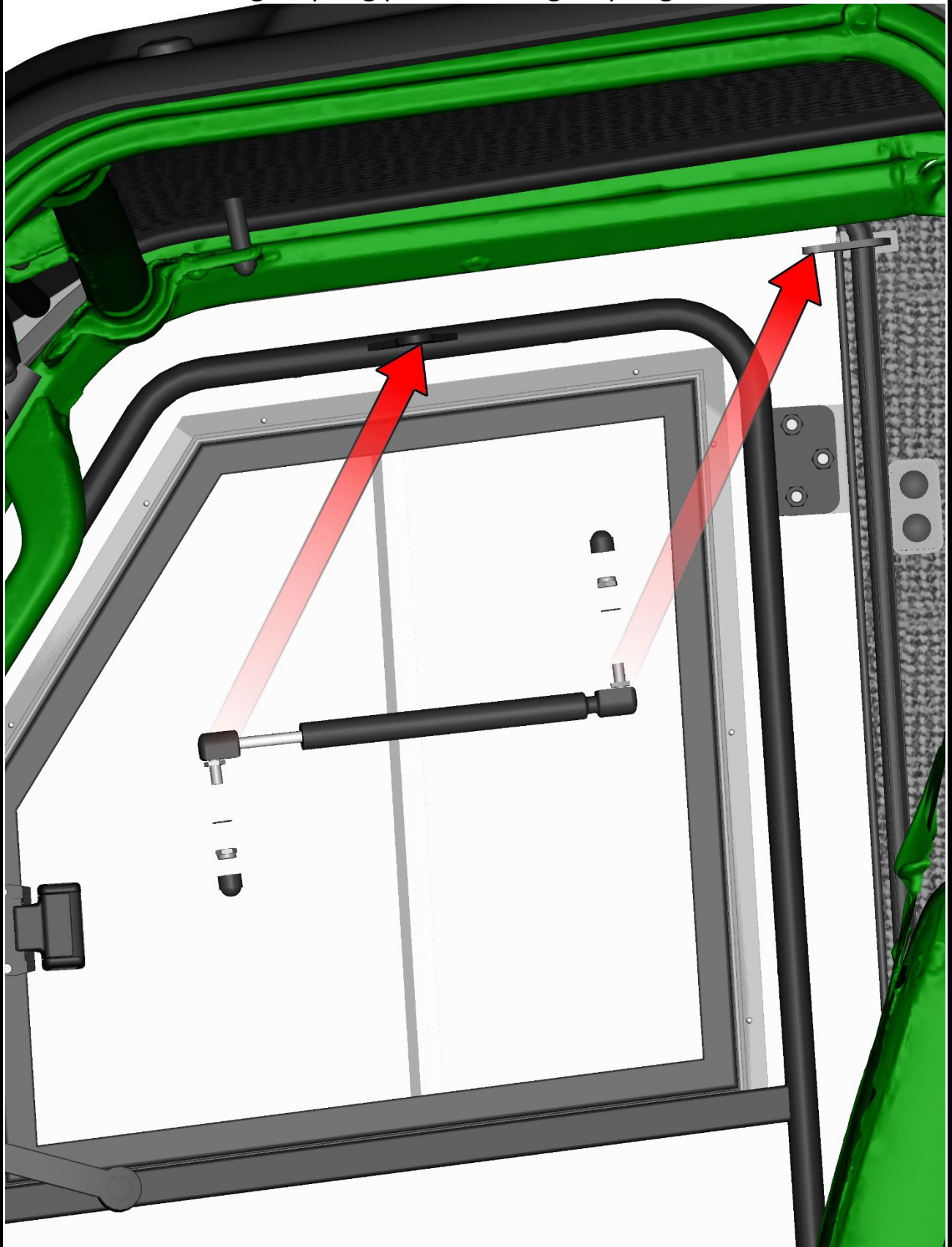

65

Place the front cover onto the vehicle body. Fix the front cover with the vehicle by included screws and tube.

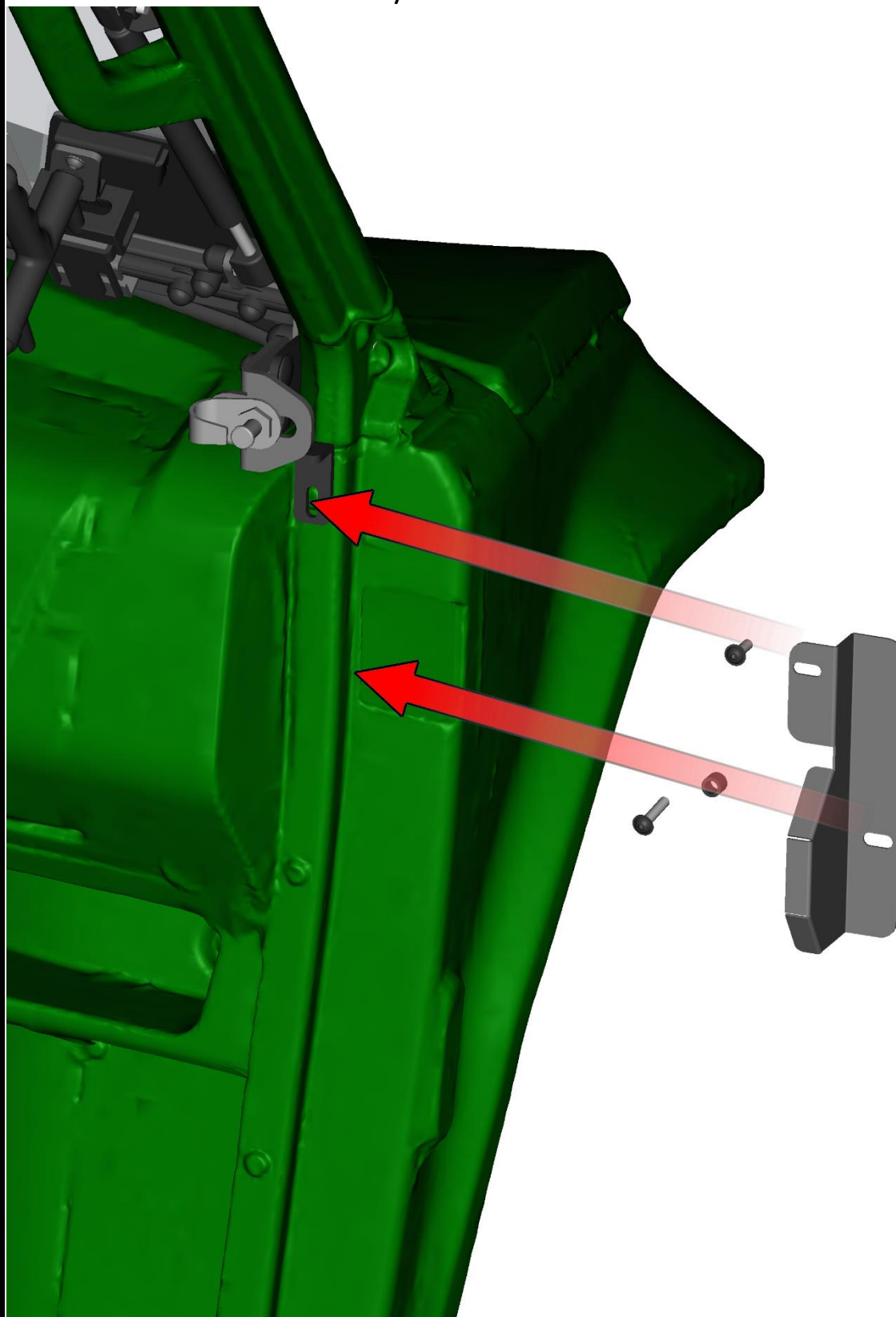

Adjust the cover to the best position. It is necessary to cover will not collide with the door.

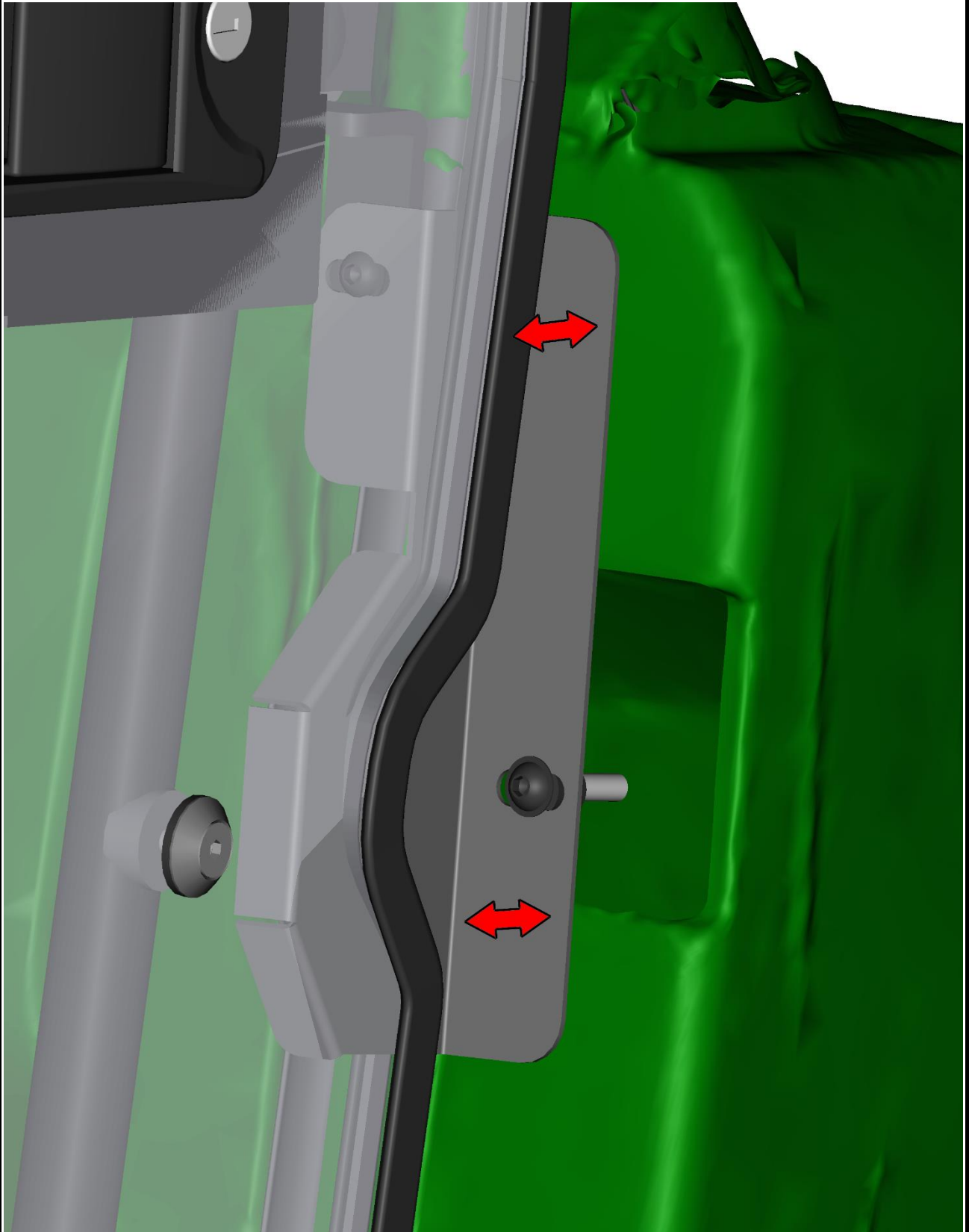

67

Repeat previous steps on the left side of the vehicle.

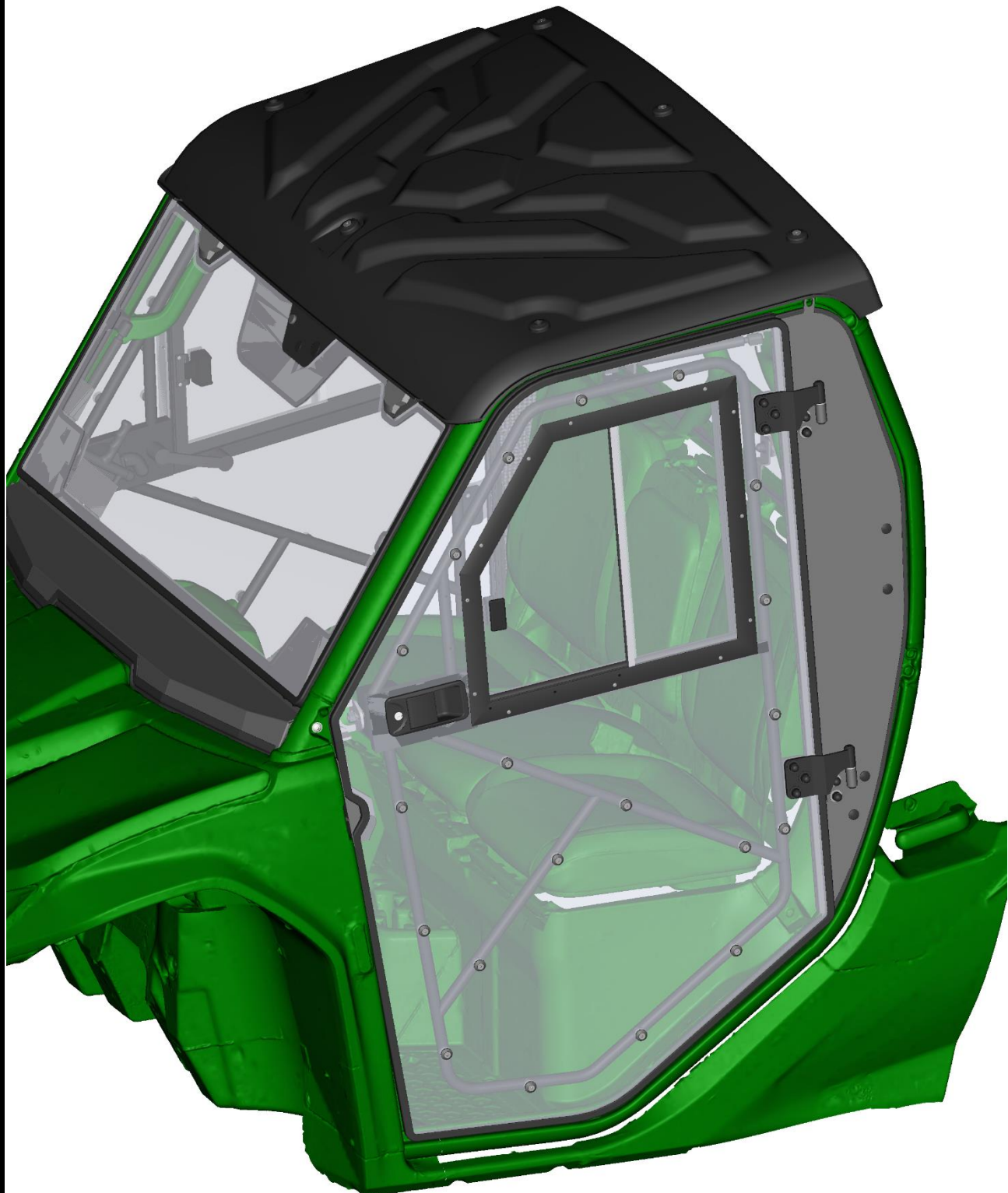

Take out the screws and washers from the door. Place the side mirror with the holder onto the door. Fix the mirror holder with the door by screws and washer from previous step. Repeat on second side.

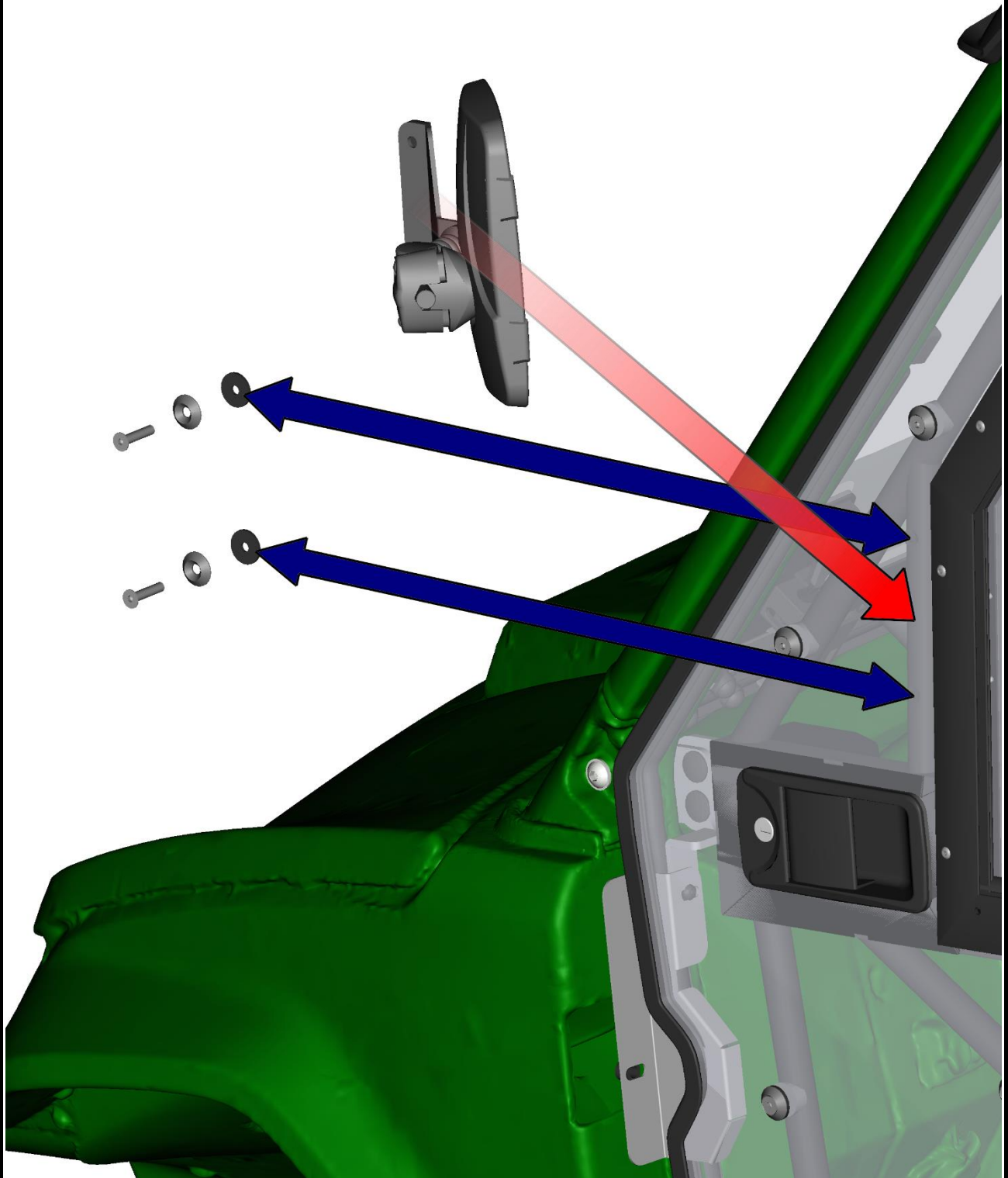

Make sure all screws and nuts are tightened correctly.

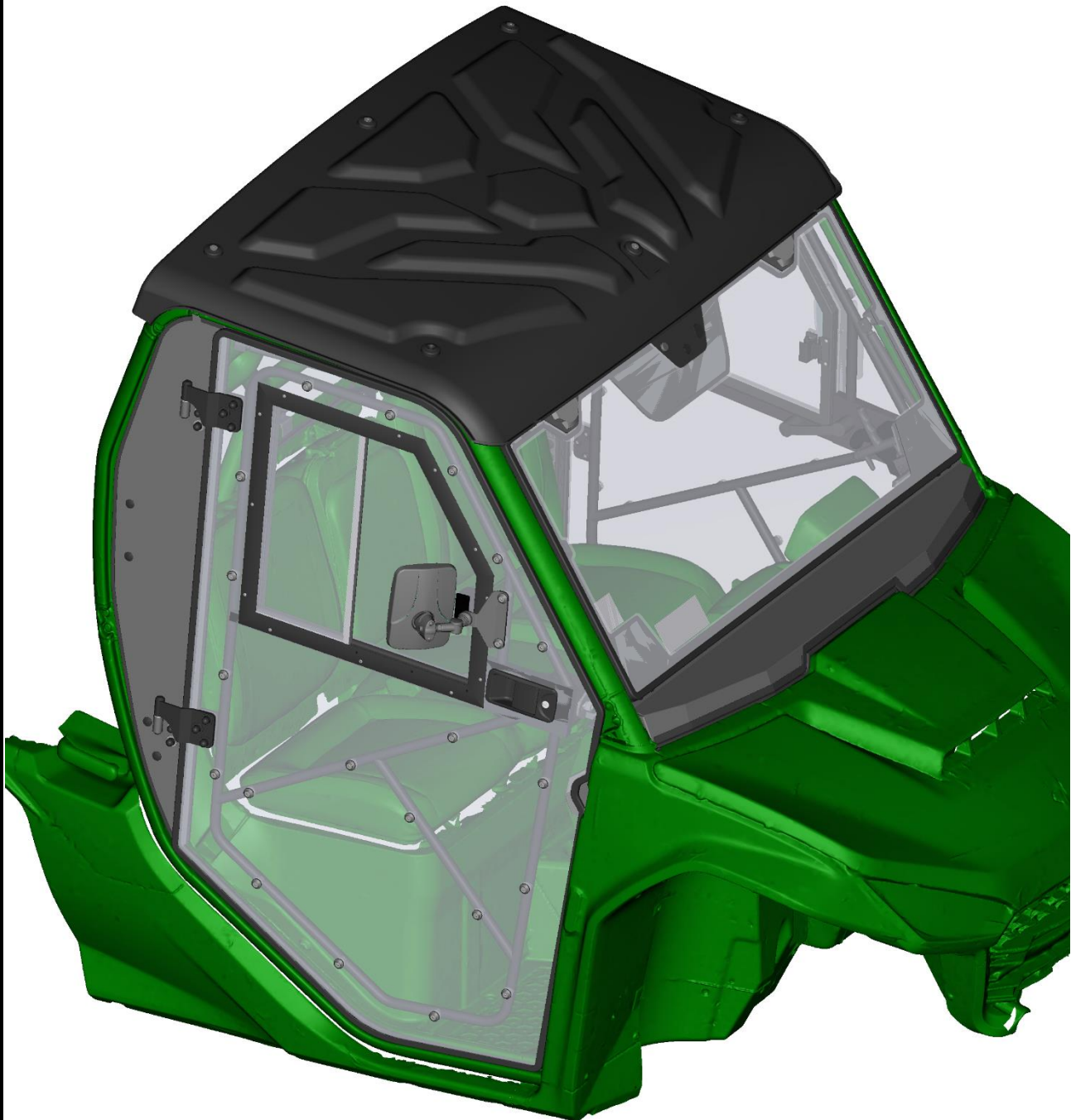

ELECTROINSTALLATION 2.

Run the wiper harness from the rear vehicle frame to the front panel.



Run the wiper harness from the rear vehicle frame to the front panel.



Install the wiper motor assembly onto the front window.
Connect the wiper harness and washer hose with the wiper motor.



Fill the washer liquid into the washer tank before first usage.

BOLT TORQUE

BOLT TORQUE SPECIFICATIONS

GENERAL TORQUE SPECIFICATION TABLE

Use the following torques when special torques are not given. These values apply to fasteners as received from suppliers, dry, or when lubricated with normal engine oil. They do not apply if special graphited or moly disulphide greases or other extreme pressure lubricants are used. This applies to both UNF and UNC threads. Remember to always use grade five or better when replacing bolts.

IMPORTANT: On all PLATED GRADE 8 bolts, reduce torque 15% from listed bolt torque specification.

SAE Grade No.		2				5				8*			
Bolt head identification mark as per grade. NOTE: Manufacturing Marks Will Vary													
		TORQUE		TORQUE		TORQUE		TORQUE		TORQUE		TORQUE	
Bolt Size		Pounds Feet		Newton-Meters		Pounds Feet		Newton-Meters		Pounds Feet		Newton-Meters	
Inches	Millimeters	Min.	Max.	Min.	Max.	Min.	Max.	Min.	Max.	Min.	Max.	Min.	Max.
1/4	6.35	5	6	7	8	9	11	12	15	12	15	16	20
5/16	7.94	10	12	14	16	17	20.5	23	28	24	29	33	39
3/8	9.53	20	23	27	31	35	42	48	57	45	54	61	73
7/16	11.11	30	35	41	47	54	64	73	87	70	84	95	114
1/2	12.70	45	52	61	70	80	96	109	130	110	132	149	179
9/16	14.29	65	75	88	102	110	132	149	179	160	192	217	260
5/8	15.88	95	105	129	142	150	180	203	244	220	264	298	358
3/4	19.05	150	185	203	251	270	324	366	439	380	456	515	618
7/8	22.23	160	200	217	271	400	480	542	651	600	720	814	976
1	25.40	250	300	339	406	580	696	787	944	900	1080	1220	1464
1-1/8	25.58	-	-	-	-	800	880	1085	1193	1280	1440	1736	1953
1-1/4	31.75	-	-	-	-	1120	1240	1519	1681	1820	2000	2468	2712
1-3/8	34.93	-	-	-	-	1460	1680	1980	2278	2380	2720	3227	3688
1-1/2	38.10	-	-	-	-	1940	2200	2631	2983	3160	3560	4285	4827

*Thick Nuts must be used with Grade 8 bolts

METRIC BOLT TORQUE SPECIFICATIONS

Size of Screw	Property Class	Course Thread			Fine Thread		
		Pitch (mm)	Pounds Feet	Newton-Meters	Pitch (mm)	Pounds Feet	Newton-Meters
M6	5.6	1.0	3.6-5.8	4.9-7.9	-	-	-
	8.8		5.8-9.4	7.9-12.7		-	-
	10.9		7.2-10	9.8-13.6		-	-
M8	5.6	1.25	7.2-14	9.8-19	1.0	12-17	16.3-23
	8.8		17-22	23-29.8		19-27	25.7-36.6
	10.9		20-26	27.1-35.2		22-31	29.8-42
M10	5.6	1.5	20-25	27.1-33.9	1.25	20-29	27.1-39.3
	8.8		34-40	46.1-54.2		35-47	47.4-63.7
	10.9		38-46	51.5-62.3		40-52	54.2-70.5
M12	5.6	1.75	28-34	37.9-46.1	1.25	31-41	42-55.6
	8.8		51-59	69.1-79.9		55-68	75.9-92.1
	10.9		57-66	77.2-89.4		62-75	84-101.6
M14	5.6	2.0	49-56	66.4-75.9	1.5	52-64	70.5-86.7
	8.8		81-93	109.8-126		90-106	122-143.6
	10.9		96-109	130.1-147.7		107-124	145-168
M16	5.6	2.0	67-77	90.8-104.3	1.5	69-83	93.6-112.5
	8.8		116-130	157.2-176.2		120-138	162.6-187
	10.9		129-145	174.8-196.5		140-158	189.7-214.1
M18	5.6	2.0	88-100	119.2-136	1.5	100-117	136-158.5
	8.8		150-168	203.3-227.6		177-199	239.8-269.6
	10.9		175-194	237.1-262.9		202-231	273.7-313
M20	5.6	2.5	108-130	146.3-176.2	1.5	132-150	178.9-203.3
	8.8		186-205	252-277.8		206-242	279.1-327.9
	10.9		213-249	288.6-337.4		246-289	333.3-391.6



Declaration of Conformity



DFK Cab, s.r.o.

Za Olšávkou 391
686 01 Uherské Hradiště
Česká republika / Czech Republic